रबड़ मिश्रित नारियल के रेशे की सांचे में
ढली गद्दी बनाने के लिए विनिर्देशन

(पहला पुनरीक्षण)

**Specification for Moulded
Rubberized Coir Cushioning**

(*First Revision*)

ICS 55.040; 59.060.10; 59.080.40

© BIS 2020



भारतीय मानक ब्यूरो
BUREAU OF INDIAN STANDARDS
मानक भवन, 9 बहादुरशाह ज़फर मार्ग, नई दिल्ली – 110002
MANAK BHAVAN, 9 BAHADUR SHAH ZAFAR MARG
NEW DELHI-110002
www.bis.gov.in www.standardsbis.in

March 2020

Price Group 6

FOREWORD

This Indian Standard (First Revision) was adopted by the Bureau of Indian Standards, after the draft finalized by the Coir and Coir Products Sectional Committee had been approved by the Textile Division Council.

This standard was first published in 1984. Further it has now been revised to incorporate the additional requirements for Ecomark (optional).

This standard covers requirements for moulded rubberized coir cushions. Requirements for rubberized coir sheets for cushioning (mattresses) have been separately covered in IS 8391.

In the formulation of this specification, assistance has been derived from 'IND/TC/2449 Specification for rubberized coir sheet', issued by the Chief Inspectorate of Textiles and Clothing, Ministry of Defence, Government of India.

The Ministry of Environment and Forests, Government of India has instituted a scheme for labelling environment friendly products known as 'Ecomark scheme'. This standard is based on the criteria as notified by the Government of India *vide* Gazette Notification No. 893(E), dated 18 September 2018 for labelling Coir and Coir products as environment friendly.

The Ecomark scheme is being operated by the Bureau of Indian Standards. However, to obtain the licence to use the Ecomark on a product, it is also essential to obtain BIS licence to use the Standard Mark as per the relevant Indian Standard for that product.

The composition of the Committee responsible for the formulation of this standard is given in Annex K.

For the purpose of deciding whether a particular requirement of this standard is complied with the final value, observed or calculated, expressing the result of a test or analysis shall be rounded off in accordance with IS 2: 1960 'Rules for rounding off numerical values (*revised*)'. The number of significant places retained in the rounded off value should be the same as that of the specified value in this standard.

Indian Standard

SPECIFICATION FOR MOULDED RUBBERIZED COIR CUSHIONING

(First Revision)

1 SCOPE

1.1 This standard prescribes requirements and methods of test for resilient moulded rubberized coir cushioning for use as seats, backrests and other cushionings.

1.2 It does not cover rubberized coir sheets which is covered in IS 8391 or other articles made from rubberized coir, such as, fabricated articles, rubberized coir sheets enclosing springs, industrial and packing materials.

2 REFERENCES

The standards listed in Annex A contain provisions which through reference in this text, constitute provision of this standard. At the time of publication, the editions indicated were valid. All standards are subject to revision, and parties to agreements based on this standard are encouraged to investigate the possibility of applying the most recent editions of the standards.

3 TERMS AND DEFINITIONS

For the purpose of this standard, the following definitions shall apply.

3.1 Moulded Rubberized Coir — A resilient product of porous structure containing curled coir fibre coated and bonded with natural rubber, synthetic rubber or a combination of both containing suitable ingredients and formed to the desired size and shape in moulds and vulcanized for the final set.

3.2 Indentation Hardness Index — The indentation is the load in kg required to produce an indentation equivalent to 40 percent of the original thickness of the sample measured by the method described in Annex E.

3.3 Lot — All rubberized coir products of the same size and shape, manufactured under similar conditions shall constitute a lot.

3.4 Sample — That part of the lot which is drawn to represent the lot.

3.5 Test Specimen — A piece taken from the sample for use in a physical or chemical test.

4 MATERIAL

4.1 Moulded rubberized coir products shall be manufactured using coir fibre curled to effectively utilize the resiliency of the fibre material, the fibres being bonded to each other by vulcanized rubber utilizing rubber latex containing vulcanizing ingredients and suitable antioxidants of such nature and quality that the finished product complies with the requirements of this specification.

4.2 Reinforcement of Edges — The moulded rubberized coir cushions shall be reinforced at the edges with strips of latex coated curled coir fleeces up to 25 mm width at the edges and the apparent density at the edges as determined by the method described in Annex C shall not exceed 120 g/dm³ for seats and 100 g/dm³ for backrests.

5 MANUFACTURE, WORKMANSHIP AND FINISH

5.1 Moulded rubberized coir products shall be of resilient nature and porous structure and shall have reinforced edges up to 25 mm width at the edges around. The surface of the cushions shall be provided with calendared surface with higher rubber latex content, at least about 2 mm deep on all sides other than bottom and shall present uniform appearance throughout and shall not contain loose fibres or voids. Any special characteristic other than those prescribed in the specification, which may be desired for specific application, shall be as agreed to between the purchaser and the supplier.

5.2 The moulded rubberized coir products shall present uniform appearance and shall not contain loose fibres or voids,

5.3 Due to manufacturing conditions the material may have to be altered or repaired. The altered material shall be acceptable provided the material used in such repairs or alteration is of the same composition and quality as the original product and provided such alterations do not affect the requirements given in the specification.

5.4 Odour

The odour of moulded rubberized coir shall be as mild as possible and shall not be objectionable.

6 SHAPE AND DIMENSIONS

6.1 Moulded rubberized coir products may be supplied in any size and shape.

6.2 The dimensions of moulded rubberized coir products when tested according to the method prescribed in Annex D shall be as specified by the purchaser subject to tolerance given below:

<i>Length or width</i>	<i>Permissible Tolerance</i>
	<i>mm</i>
Up to 1 m	± 5
1 to 1.5 m	± 7
Over 1.5 m	± 9
<i>Thickness</i>	
Thickness up to 12 mm	± 3
Over 12 mm up to 38 mm	+6
	-3
Over 38 mm	+12
	-5

7 PERFORMANCE REQUIREMENTS

7.1 Standard Conditions

The sample selected and prepared for test as in Annex B shall be conditioned for a minimum period of 24 h at 27 ± 2°C and 65 ± 5 percent relative humidity (see IS 196) prior to testing and testing shall be in the same atmosphere, when the testing cannot be carried out in the same atmosphere, then the testing shall be commenced within 2 min of withdrawal of specimen from the conditioning atmosphere.

7.2 Indentation Hardness

When tested according to the method given in Annex E, moulded rubberized coir products shall have the indentation hardness as given below unless otherwise agreed to between the supplier and the purchaser.

<i>Indentation Hardness Index</i>	
Seat cushions of 50 mm thickness and above	10
Backrests of 50 mm thickness and above	8

} ± 20 percent

7.3 Apparent Density

7.3.1 The apparent density of the moulded rubberized coir seat cushions and backrests below 50 mm thickness shall be as follows when tested according to Annex C:

Apparent Density, g/dm³	
Seat cushions	100
Backrests	90

} ± 15 percent

7.3.2 The apparent density of the moulded rubberized coir seat cushions and backrests of 50 mm thickness and above shall be as follows when tested according to Annex C:

Apparent Density, g/dm³	
Max	
Seat cushions	100
Backrests	80

7.3.3 The apparent density of the material at the edges of the cushions up to 25 mm portion from the edges shall not exceed 120 g/dm³ for seats and 100 g/dm³ for backrests.

NOTE — For mouldings of irregular shape the mass per piece shall be as prescribed by the buyer.

7.4 Resistance to Ageing

When tested according to the method prescribed in Annex F, the indentation hardness of sample after ageing shall not vary by more than ± 20 percent of the value obtained with unaged sample.

7.5 Resistance to Flexing

When tested according to the method given in Annex G, the indentation hardness of the test specimen shall not vary by more than ± 25 percent. This shall be calculated on the resultant thickness.

7.6 Compression Set

The compression set of the sample determined by the method prescribed in Annex H, shall not exceed 25 percent. When tested under normal atmospheric conditions the compression set shall not exceed 15 percent after 3 h of recovery.

7.7 pH Value

pH value of aqueous extract of the material when determined by the method prescribed in Annex J, shall be within 5 to 8.5.

7.8 Chloride Content

The chloride content of the material calculated as chlorine when determined by the method prescribed in Annex J, shall not exceed 0.3 percent by mass.

7.9 Sulphate Content

The sulphate content of the aqueous extract of the material prepared as in J-2 and tested by the method prescribed in IS 2317 shall not exceed 0.2 percent by mass.

8 ADDITIONAL REQUIREMENTS FOR ECOMARK (OPTIONAL)

8.1 The product(s) shall meet the requirement specified in this Indian Standard.

8.2 The manufacturer shall produce the consent clearance as per the provisions of *Water (Prevention and Control of Pollution) Act, 1974* and *Air (Prevention and Control of Pollution) Act, 1981* and the authorization(s), if required under the rules notified under the *Environment (Protection) Act, 1986* and the rules made there under while applying for the Ecomark as per *Bureau of Indian Standards Act, 2016*.

8.3 The product(s) or product packaging(s) may display in brief the criteria based on which the product(s) has/have been labeled environment friendly.

8.4 The material used for product packaging(s) shall be recyclable, reusable or biodegradable.

8.5 The product shall meet the specific requirements as given in Table 1.'

Table 1 Specific Requirements for Ecomark (Optional)
(Clause 8.5)

SI No.	Parameter	Requirement	Method of Test
(1)	(2)	(3)	(4)
i)	Residual pesticides (Sum parameter) (ppm) (Max)	1.0	IS 15651
ii)	pH of aqueous extract	6-7	IS 8391 (Part 1)

9 MARKING

9.1 Moulded rubberized coir products shall be legibly and indelibly marked or a label giving the following particulars shall be attached to it:

- Grade;
- Dimensions;
- Manufacturer's name, initials, trade-mark or any other identification mark; and
- Criteria for which rubberized coir sheets has been labeled as Ecomark.

9.2 BIS Certification Marking

The product(s) conforming to the requirements of this standard may be certified as per the conformity

assessment schemes under the provisions of the *Bureau of Indian Standards Act, 2016* and the Rules and Regulations framed thereunder, and the products may be marked with the Standard Mark.

10 PACKING

The moulded rubberized coir products shall be packed as agreed to between the purchaser and the supplier.

11 INSTRUCTIONS FOR STORAGE

Moulded rubberized coir products shall be kept in well ventilated store in an atmosphere free from combustion from any heating appliance and solvent vapours out of contact with damp surface. Under no circumstances shall the product be stored in direct from sunlight or exposed to ultraviolet light. When products are stacked in stores, care shall be taken to avoid undue compression or distortion.

12 SAMPLING AND CRITERIA FOR CONFORMITY

12.1 Unless otherwise agreed to between the buyer and the seller, the number of rubberized coir cushions selected from a lot shall be according to column 1 and 2 of Table 2. The cushions shall be selected at random and in order to ensure the randomness of selection, methods given in IS 4905 shall be followed.

Table 2 Sample Size

Lot Size	No. of Cushions to be Selected	Sub-Sample Sizes
(1)	(2)	(3)
Up to 100	5	1
101 to 300	8	2
301 to 500	13	2
500 and above	20	3

12.2 The cushions selected according to **12.1** shall be inspected for dimensions that is, length, width and thickness. The lot shall be considered conforming to the requirements of the dimensions if all the cushions satisfy the relevant requirements.

12.3 From the lots found satisfactory for dimensions, the number of cushions to be taken for physical and chemical tests shall be according to column 3 of Table 2. One test specimen shall be prepared for testing of each of the characteristics. In case the size of the cushion is not adequate for drawing the test specimen, additional cushions may be drawn.

12.4 The lot shall be considered conforming to the requirement of the standard if all the test specimens meet the relevant requirements.

ANNEX A

(Clause 2)

LIST OF REFERRED INDIAN STANDARDS

<i>IS No.</i>	<i>Title</i>	<i>IS No.</i>	<i>Title</i>
196 : 1966	Atmospheric conditions for testing	1070 : 1992	Reagent grade water — Specification (<i>third revision</i>)
2317 : 1975	Method for gravimetric determination of sulphates (<i>first revision</i>)	15651 : 2006	Textiles — Requirements for environmental labelling — Specification
4905 : 2015	Random sampling and randomization procedures (<i>first revision</i>)	8391 (Part 1) : 2018	Rubberized coir sheets for cushioning — Specification: Part 1 Curled (<i>second revision</i>)

ANNEX B

(Clause 7.1)

METHOD OF PREPARATION OF THE TEST SAMPLE

B-1 The specimen shall be cut to size 100 × 100 mm as far as possible from the center of the sampling piece leaving a minimum of 50 mm width all around. For determination of apparent density at the edge, the test specimen shall be 100 mm long and 25 mm wide along the edges of the sample leaving 50 mm from the corners. Wherever practicable apparent density shall be determined on the whole sample.

B-2 In case of oversize samples which are not amenable for being accommodated in the conditioning chamber, suitable portion of the samples large enough to be contained in the chamber and adequate to reflect

the characteristics of the sample may be cut and conditioned.

B-3 When differences due to the difficulty in obtaining suitable test pieces from the finished product arise, the manufacturer and the purchaser may agree on acceptable deviations.

B-4 Test shall be carried out not before 48 h after vulcanization of the sample. The samples and test pieces shall be protected from light as completely as possible and from any stress or strain whenever they are not actually in the process of being tested.

ANNEX C

(Clauses 4.2, 7.3.1 and 7.3.2)

METHOD FOR DETERMINATION OF APPARENT DENSITY

C-1 METHOD

C-1.1 Determine the length, width and thickness of the test sample as described in Annex D.

C-1.2 Weigh the test sample correct to 0.1 g.

C-1.3 Determine the density of the specimen by dividing the mass in grammes by the volume in cubic decimetre.

C-1.4 In the case of mouldings of irregular shape that are not amenable to measurement of volume the

apparent density shall be determined on the mass and volume of a test specimen of appropriate size cut out from suitable location of the sample.

C-1.5 To determine the apparent density at the edges, the test specimen shall be 100 mm long and 25 mm wide along the edges; the length, width and thickness being determined to the nearest millimetre. Weigh the test specimen correct to 0.1 g and determine the density by dividing the mass in grams by volume in cubic decimetre.

ANNEX D

(Clause 6.2)

METHOD OF TEST FOR MEASUREMENT OF DIMENSIONS

D-1 DETERMINATION OF LENGTH AND WIDTH

Measure the length and width of the sample using a steel rule nearest to 1 mm, ensuring the measurement along the line perpendicular to opposing faces of the sample.

D-2 DETERMINATION OF THICKNESS

D-2.1 A test specimen 100 × 100 mm cut out from the sample leaving a minimum width to 50 mm all round

shall be placed between two larger horizontal plates suitably loaded so as to obtain the original thickness of the moulded cushioning. The distance between the plates is determined at about the middle of each side correct to the nearest millimeter and the average of four readings taken as the thickness of the sample.

D-2.2 The thickness shall be measured with reference to the order and or the drawing accompanying the order. In the absence of the order and or the drawing accompanying the order the thickness shall be measured with reference to the declaration by the manufacturers.

ANNEX E

(Clauses 3.2 and 7.2)

METHOD FOR DETERMINATION OF INDENTATION HARDNESS

E-1 SAMPLE

E-1.1 Cut out a test specimen measuring 100 × 100 mm leaving a space of 25 mm from the edges of the whole piece, from the portion where the original thickness was measured as per **D-2.2**.

E-1.2 Sample shall not be tested less than 48 h after having been vulcanized. They shall be stored for 24 h immediately before testing, at a temperature of $27 \pm 2^\circ\text{C}$ and 65 ± 5 percent relative humidity. The test shall also be conducted under similar conditions.

E-2 APPARATUS

E-2.1 The testing apparatus shall be capable of applying an indenter in such a way that the load applied on the sample shall be at the rate of 0.5 kgf/min and shall have a dial scale platform balance of suitable capacity for measuring the load required to produce the specified indentation. The sample shall be placed on the smooth flat horizontal surface of the platform of the dial scale balance, the surface of the platform being larger than the size of the sample.

E-2.2 The essential parts of the testing apparatus (see Fig. 1) are an adjustable indenter of the dimension specified in **E-2.2.1**, which can be moved vertically up or down by a threaded shaft working through a sleeve of same pitch and dimension, operated by a hand wheel. The sleeve is fitted to a framework which rests on the horizontal surface of a table without having contact

with the platform of a dial scale balance of 20 kg capacity graduated in 50 g sub-division. The thickness of the sample can be measured by means of a pointer mounted on the indenter

With suitable guides and sliding in front of a vertical scale graduated in millimeters. The pointer is so adjusted that when the indenter touches platform of the balance, the reading of the pointer on the scale is zero.

E-2.2.1 Indenter

A 105 × 105 mm mild steel plate of 3 mm thickness shall constitute the indenter, fitted to the threaded shaft by a ball and socket joint, so that the surface of the indenter can adjust itself to the contour of the test specimen.

E-3 TEST PROCEDURE

The test specimen shall be of size 100 × 100 mm cut out from the portion where the original thickness was determined. Raise the indenter to a height greater than the thickness of the sample and place the sample over the platform of the balance below the indenter. Lower the indenter by rotating the handle so as to press the sample to its original thickness as determined in **D-2.1** and note the load as W_1 . Gradually lower the indenter to apply a load at the rate of 0.5 kgf/min until the sample is pressed to 60 percent of its original thickness. The load recorded is to be noted as W_2 . The difference between W_2 and W_1 shall be taken as indentation hardness index of the specimen.

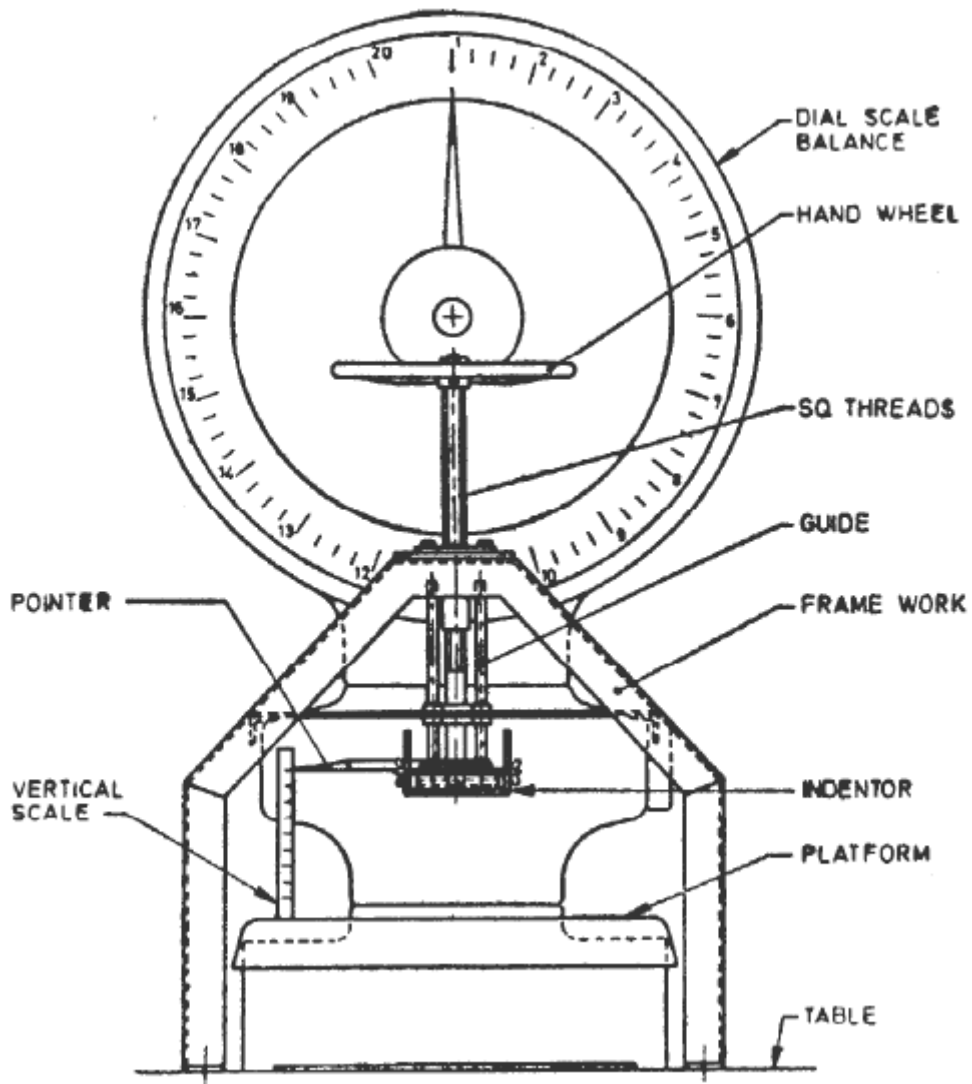

FIG. 1 APPARATUS FOR INDENTATION TEST

ANNEX F

(Clause 7.4)

METHOD FOR DETERMINATION OF RESISTANCE TO AGEING

F-1 GENERAL

F-1.1 The ageing test consists in subjecting samples to controlled deterioration by air at elevated temperature and atmospheric pressure after which the physical properties are measured and compared with those of unaged samples. The deterioration is measured by the observed change in the physical properties concerned

in the service application of the article as determined by visual examination.

F-1.2 The sample used in any of the ageing test shall be that required for the particular determination which is to be employed for measuring the effect of ageing exposure. Only samples having approximately the same dimensions shall be compared with each other.

F-2 PROCEDURE

F-2.1 Arrange for an air oven of such size that the total volume of test pieces does not exceed 10 percent of the free space in the oven. Make provision for suspending samples so that they are not within 12 mm of each other or the oven sides. Control the temperature of the oven thermostatically so that the test pieces are kept at $70 \pm 2^\circ\text{C}$. Place thermometer near the centre of the oven to record the actual ageing temperature.

F-2.2 Adjust the oven to $70 \pm 2^\circ\text{C}$. Place the test pieces in the oven adjusted as indicated in **F-2.1**. Arrange the test pieces so that they are stationary, free from strain, freely exposed to air from all sides and not exposed to light. Continue the ageing for 48 h. Test the unaged test piece within the same 24 h period as that in which ageing commences. At the completion of the ageing period, remove the test pieces from the oven and place on a flat surface to cool at room temperature. Allow them to cool for not less than 24 h. Measure the indentation hardness of the aged sample as in Annex E.

ANNEX G

(Clause 7.5)

METHOD FOR DETERMINATION OF RESISTANCE TO FLEXING**G-1 METHOD**

The method involves submitting a sample to continued flexing with an indenter for 250 000 cycles at the rate of 4 cycles per second and measuring the loss in hardness.

G-2 SAMPLE

G-2.1 Cut out a test specimen measuring 100 x 100 mm, leaving 25 mm from the edges of the whole piece from a region where the original thickness was determined.

G-2.2 Sample shall not be tested less than 48 h after having been vulcanized. They shall be stored for at least 24 h immediately before testing, at a temperature of $27 \pm 2^\circ\text{C}$ and 65 ± 5 percent relative humidity. The test shall also be conducted under similar conditions.

G-3 APPARATUS

G-3.1 The essential part of one apparatus (*see* Fig. 2) which has been found suitable, consists of an indenter of dimensions specified in **F-3.2**, connected through a threaded adapter and held by a locking nut to a pushrod. This push rod is constrained to move vertically by fixed sleeves and is driven vertically by a motor which rotates a crank disc. The crank disc and push rod being joined by a connecting rod. This connecting rod is adjustably mounted in a radial slit in the crank disc, the length of the strokes therefore, being adjustable. The motor is mounted upon a steel beam above the table upon which the specimen to be tested is placed. A square

frame made of mild steel angles with a clear internal dimension of 107×107 mm is positioned on the table just below the indenter to prevent lateral movement of the specimen in the course of its repeated flexing by the indenter. The fixtures are adjusted for effecting 4 flexes/s. A revolution counter is attached to the machine to record the number of flexes for the specimen.

G-3.2 A 105 x 105 mm mild steel plate of 3 mm thickness shall constitute the indenter.

G-4 PROCEDURE

Measure the thickness of the sample as described in **D-2**. Determine the hardness index as given in Annex E. Adjust the stroke of the crank shaft for a depression of the indenter by a distance equal to 40 percent of the original thickness of the sample. This is done by adjusting the position of the connecting rod in the crank disc. Raise the indenter to the topmost position of the stroke and place the test specimen in the mild steel angle box below the indenter. Place wooden blocks of suitable thickness below the specimen to ensure that the top surface of the specimen is in contact with the bottom side of the indenter when the indenter is at the topmost position of the stroke. Subject the specimen to flexing at a rate of 4 flexes per second. After flexing 250 000 cycles, allow the sample to remain for 30 min. Thereafter, determine the indentation hardness by test described in Annex E. This variation in the indentation hardness is calculated as percentage of the initial hardness index.

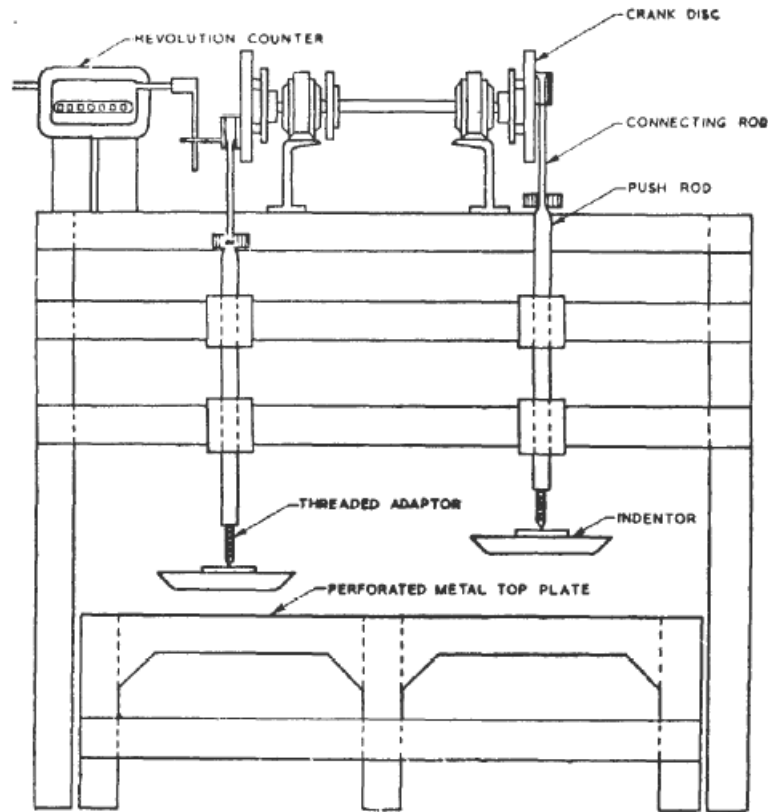

FIG. 1 APPARATUS FOR FLEXING TEST

ANNEX H

(Clause 7.6)

METHOD FOR DETERMINATION OF COMPRESSION SET

H-1 METHOD

H-1.1 The compression set under constant deflection is the residual strain in a test piece after it has been strained under compression to a given extent for a given time and then allowed to recover for a given time, the temperature being substantially constant during the test.

H-1.2 The test piece shall be of size 100 × 100 mm.

H-2 APPARATUS

The compression device shall consist of two flat steel plates between the parallel faces of which the test piece is compressed. Steel spacers in the form of bars and of thickness such as to give the required 40 percent compression shall be provided to control the thickness of the test piece during the test.

H-3 PROCEDURE

H-3.1 Measure accurately the initial thickness of the test piece as in **D-2**. Compress the test piece by 40 percent of its original thickness between the parallel

steel plates, which shall be larger than the test piece. Use steel spacers, between the plates, sufficient clearance being allowed for tilting of the test piece and care being taken to avoid displacement of the test piece. After being compressed for 22 h at a temperature of 70 ± 2°C remove the test piece from the clamp while still at the test temperature and allow to recovering for 3 h at room temperature. Then measure the thickness of the test piece again. Test at least two test pieces and take the average of test results.

H-3.1.1 Calculation

Calculate the compression set as follows:

Compression set at constant strain, percent =

$$\frac{T_0 - T_1}{T_0} \times 100$$

Where,

T_0 = Original thickness of the test piece, and

T_1 = Thickness of the test piece after recovery.

ANNEX J

(Clauses 7.7 and 7.8)

METHOD FOR DETERMINATION OF pH VALUE AND CHLORIDE CONTENT

J-1 TEST SPECIMENS

Draw a square piece of rubberized coir product weighing about 10 g.

J-2 PREPARATION OF AQUEOUS EXTRACT

Cut the piece taken into about 5 mm square pieces and weigh. Transfer to a clean, chemically resistant glass flask, fitted with ground glass joint for reflux condenser. Add distilled water (*see* IS 1070) weighing 20 times the mass of the rubberized coir under test, to the flask. Fit the flask to the reflux condenser and heat the contents of the flask to boil. Continue boiling for one hour. Remove the flask and close while the liquid is still boiling gently using a clean ground glass stopper. Cool to room temperature.

J-3 DETERMINATION OF pH VALUE

Transfer a portion of the water extract to the electrode of pH meter and determine the pH.

J-4 DETERMINATION OF CHLORIDE CONTENT**J-4.1 Principle**

Chlorides are determined volumetrically by titration with standard silver nitrate solution.

J-4.2 Reagents**J-4.2.1 Calcium Carbonate****J-4.2.2 Standard Silver Nitrate Solution, 0.1 N.****J-4.3 Procedure**

Take a portion of the aqueous extract prepared as in J-2. Neutralize with calcium carbonate till a pale yellow colour is obtained (usually 0.5g is sufficient). Titrate with standard silver nitrate solution till a red colour is obtained.

J-4.4 Calculation

Chloride (as Cl), percent by mass = $\frac{3.456 (V_1 - V_2)N}{W}$

Where,

V_1 = Volume (ml) of standard silver nitrate solution used in the titration with the material,

V_2 = Volume (ml) of standard silver nitrate solution used in the blank determination,

N = Normality of standard silver nitrate solution, and

W = Mass (g) of the material taken for test.

ANNEX K

(Foreword)

COMMITTEE COMPOSITION

Coir and Coir Products Sectional Committee, TXD 25

<i>Organization</i>	<i>Representative(s)</i>
Central Coir Research Institute, Kalavoor	DR ANITA DAS RAVINDRANATH (Chairman) SMT SUMI SEBASTIAN (<i>Alternate</i>)
Coir Pith and Allied Products Manufacturers and Exporters Association, Coimbatore	PRESIDENT SECRETARY (<i>Alternate</i>)
All India Rubberized Coir Products Manufacturers Association, Tirunelveli	SHRI SUNDARESAN SHRI MATHEW GEORGE (<i>Alternate</i>)
Central Institute of Coir Technology, Bengaluru	JOINT DIRECTOR SENIOR SCIENTIFIC OFFICER (<i>Alternate</i>)
Coconut Development Board, Ernakulam	SHRI SUGATA GHOSH DR K. MURALIDHARAN (<i>Alternate</i>)
Coir board, Kkochi	SECRETARY JOINT DIRECTOR (<i>Alternate</i>)
Coir Mats and Mattings Association, Ernakulam	SHRI V. A. JOEPH SHRI PAVITHRAN (<i>Alternate</i>)
Coir on Foam Products, Coimbatore	SHRI HARIRAJAN SHRI PHILIP VARGHESE (<i>Alternate</i>)
Coir Shippers' Council, Cherthala	SHRI K. S. SANJEEV SHRI SAJAN B. NAIR (<i>Alternate</i>)
Federation of Indian Coir Exporters' Associations, Alleppey	SHRIJOSPALU MATHEW SHRI SAJAN B. NAIR (<i>Alternate</i>)
Hindustan Coir, Coir Board Complex Alappuzha	WEAVING MASTER SENIOR SCIENTIFIC OFFICER (<i>Alternate</i>)
Karnataka State Coir Development Corporation Ltd, Bangalore	SHRI G. KUMARASWAMY SHRI K. R. KUMARASWAMY (<i>Alternate</i>)
Kerala Organic Manure and Fertilizer	SHRI G. RAJESH
Kerala State Coir Corporation Ltd, Alappuzha	SHRI G. SREEKUMAR SHRI N. SUNURAJ (<i>Alternate</i>)
Kerala State Small Scale Coir Manufacturer's Federation, Alappuzha	PRESIDENT SECRETARY (<i>Alternate</i>)
Kerala State Coir Marketing Federation	SHRI SURESH KUMAR
Kurlon Enterprises Limited, Bangalore	SHRI NARENDRA KUDVA SHRI P. ANIL (<i>Alternate</i>)
M M Rubber & Co, Chennai	SHRI JOSEPH CHERIYAN
National Coir Research & Management Institute (NCRMI), Thiruvanthapuram	DR K. R. ANIL SHRI C. ABHISHEK (<i>Alternate</i>)
National Coir Training & Design Centre, Alappuzha	ASSISTANT DIRECTOR ALAPPUZHAREGIONAL OFFICER (<i>Alternate</i>)
Natural Green Tech (P) Ltd, Bengaluru	SHRI TOMMY MATHEW SHRI ABHISHEK THOMAS (<i>Alternate</i>)
Orissa Co operative Coir Corporation Ltd, Bhubaneshwar	MANAGING DIRECTOR GENERAL MANAGER (<i>Alternate</i>)

<i>Organization</i>	<i>Representative(s)</i>
Rubber Board, Kottayam	DR J. THOMAS DR JAMES JACOB (<i>Alternate</i>)
Shaa Pith Media Co, Coimbatore	SHRI S. PRABHU SHRI RAMESH (<i>Alternate</i>)
Sivanthi Joe Coirs, Tuticorin	SHRI DUNSTEN JOSEPH SHRI K. SIVAKAR (<i>Alternate</i>)
Tamil Nadu Coir Cooperative Federation, Chennai	MANAGING DIRECTOR GENERAL MANAGER (<i>Alternate</i>)
Venugopal Fibre Industries, Pattukottai	SHRI R. B. SHYAM SUNDER
BIS Directorate General	SHRI A. K. BERA, SCIENTIST 'F' AND HEAD (TXD) [REPRESENTING DIRECTOR GENERAL (<i>Ex-officio</i>)]

Member Secretary

SHRI P. N. MURALI
SCIENTIST 'D' BIS

Bureau of Indian Standards

BIS is a statutory institution established under the *Bureau of Indian Standards Act, 2016* to promote harmonious development of the activities of standardization, marking and quality certification of goods and attending to connected matters in the country.

Copyright

BIS has the copyright of all its publications. No part of these publications may be reproduced in any form without the prior permission in writing of BIS. This does not preclude the free use, in the course of implementing the standard, of necessary details, such as symbols and sizes, type or grade designations. Enquiries relating to copyright be addressed to the Director (Publications), BIS.

Review of Indian Standards

Amendments are issued to standards as the need arises on the basis of comments. Standards are also reviewed periodically; a standard along with amendments is reaffirmed when such review indicates that no changes are needed; if the review indicates that changes are needed, it is taken up for revision. Users of Indian Standards should ascertain that they are in possession of the latest amendments or edition by referring to the latest issue of 'BIS Catalogue' and 'Standards: Monthly Additions'.

This Indian Standard has been developed from Doc No.: TXD 25 (14748).

Amendments Issued Since Publication

Amend No.	Date of Issue	Text Affected

BUREAU OF INDIAN STANDARDS

Headquarters:

Manak Bhavan, 9 Bahadur Shah Zafar Marg, New Delhi 110002
Telephones: 2323 0131, 2323 3375, 2323 9402

Website: www.bis.gov.in

Regional Offices:

	Telephones
Central : Manak Bhavan, 9 Bahadur Shah Zafar Marg NEW DELHI 110002	{ 2323 7617 2323 3841
Eastern : 1/14 C.I.T. Scheme VII M, V.I.P. Road, Kankurgachi KOLKATA 700054	{ 2337 8499, 2337 8561 2337 8626, 2337 9120
Northern : Plot No. 4-A, Sector 27-B, Madhya Marg CHANDIGARH 160019	{ 265 0206 265 0290
Southern : C.I.T. Campus, IV Cross Road, CHENNAI 600113	{ 2254 1216, 2254 1442 2254 2519, 2254 2315
Western : Manakalaya, E9 MIDC, Marol, Andheri (East) MUMBAI 400093	{ 2832 9295, 2832 7858 2832 7891, 2832 7892

Branches: AHMEDABAD. BENGALURU. BHOPAL. BHUBANESHWAR. COIMBATORE.
DEHRADUN. DURGAPUR. FARIDABAD. GHAZIABAD. GUWAHATI.
HYDERABAD. JAIPUR. JAMMU. JAMSHEDPUR. KOCHI. LUCKNOW.
NAGPUR. PARWANOO. PATNA. PUNE. RAIPUR. RAJKOT. VISAKHAPATNAM.

Published by BIS, New Delhi