



M/s.Yuvasakthi
Implementing Agency, Andaman Coir Cluster,
Near IACT Computer Education, Opp. Calcutta
Sweet Stall, Junglighat, Port Blair – 744 103
Ph. No. 99332 88131, 95319 59146.
Email: ia.yuvasakthi@gmail.com



Tender Notice No. SFURTI-II/ANDMN/B-01/2019-20 dt.05.02.2020

Sealed Tenders are invited by **M/s.Yuvasakthi**, the Implementing Agency (IA) of **Andaman Coir Cluster**, from reputed civil contractors for the following works under the **Scheme of Fund for Regeneration of Traditional Industries (SFURTI)** of Coir Board, Ministry of MSME, Government of India.

Name of Work	EMD
Construction of Industrial work shed buildings and amenities for the common facility centre of Andaman Coir Cluster under SFURTI at Beodnabad village, Port Blair Tehsil, South Andaman District.	Rs.1,50,000/-in the form of Demand Draft drawn in favour of "HI Account Andaman Coir Cluster", payable at Port Blair.

The tender schedule can be downloaded at free of cost from the website **www.coirboard.gov.in** or **www.itcot.com** upto 5.00 PM on 27.02.2020.

The last date for submission of tenders is upto 02.00 PM on 28.02.2020 and the same will be opened on the same day at 03.00 PM. The tender document shall be submitted at the office of M/s.Yuvasakthi, Near IACT Computer Education, Opp. Calcutta Sweet Stall, Junglighat, Port Blair – 744 103, South Andaman, A & N Islands.

GENERAL SECRETARY

M/s. Yuvasakthi

(Implementing Agency - Andaman Coir Cluster)

Office: Near IACT Computer Education, MG Road, Junglighat (Post),
Port Blair, South Andaman – 744 103

Mobile: +91-99332 88131, **Email:** ia.yuvasakthi@gmail.com

TENDER REFERENCE No. SFURTI-II/ANDMN/B-01/2019-20

**TENDER FOR THE CONSTRUCTION OF
INDUSTRIAL WORK SHED BUILDINGS AND AMENITIES FOR THE
COMMON FACILITY CENTER OF ANDAMAN COIR CLUSTER**

Date & Time of Release of Tender	05.02.2020, 11.00 AM
Date & Time of Pre-Bid Meeting	17.02.2020, 11.00 AM
Last Date & Time for Submission of Bid	28.02.2020, 02.00 PM
Date & Time of Opening of Bid (Technical bid only)	28.02.2020, 03.00 PM

Technical Agency (SFURTI)

ITCOT Consultancy and Services Limited

E-mail: info@itcot.com, **Website:** www.itcot.com

CONTENTS

Clause	Topic	Page No.
1.	PREAMBLE.....	1
2.	SCOPE OF WORK	2
3.	QUALIFICATION CRITERIA.....	2
4.	LANGUAGE OF THE TENDER	3
5.	PURCHASE OF TENDER DOCUMENT.....	3
6.	PREBID MEETING	3
7.	CLARIFICATION ON THE TENDER DOCUMENT.....	4
8.	AMENDMENT OF TENDER DOCUMENT.....	4
9.	AUTHORISATION OF THE TENDERER.....	4
10.	PRE-VISIT OF SITE.....	4
11.	SPECIFIC INSTRUCTIONS TO BIDDERS/CONTRACTORS	4
12.	SUBMISSION OF TENDER IN TWO COVER SYSTEM	5
13.	EARNEST MONEY DEPOSIT	6
14.	VALIDITY	6
15.	OPENING AND EVALUATION OF THE TENDER	6
16.	PRICE OFFER	7
17.	EVALUATION OF THE PRICE	7
18.	AWARD OF CONTRACT	8
19.	SECURITY DEPOSIT	8
20.	AGREEMENT.....	8
21.	ISSUE OF WORK ORDER	8
22.	DEFECT IDENTIFICATION & RECTIFICATION.....	9
23.	EMPLOYMENT OF TECHNICAL ASSISTANTS	9
24.	PAYMENT TERMS.....	9
25.	PENALTY	10
26.	TERMINATION OF CONTRACT.....	10
27.	GENERAL CONDITIONS	10
28.	ARBITRATION	11
29.	JURISDICTION OF THE COURT.....	11

ANNEXURES

I.	BUILDING DRAWING & BOQ.....	12
II.	PART-I (COVERING LETTER).....	23
III.	DETAILS OF THE TENDERER.....	25
IV.	ANNUAL TURNOVER STATEMENT.....	26
V.	LIST OF WORKS EXECUTED IN LAST 3 YEARS	27
VI.	DECLARATION OF NOT HAVING BLACKLISTED.....	28
VII.	DECLARATION FOR NOT HAVING TAMPERED THE TENDER DOCUMENT....	29
VIII.	PART-II (COVERING LETTER).....	30
IX.	PRICE BID	31
X.	CHECKLIST OF DOCUMENTS	32

**TENDER FOR THE CONSTRUCTION OF INDUSTRIAL WORK SHED BUILDINGS
AND AMENITIES FOR ANDAMAN COIR CLUSTER**

1. PREAMBLE

Ministry of MSME, Government of India has formulated “**Scheme of Fund for Regeneration of Traditional Industries (SFURTI)**”, for the development of Village industries and Coir clusters in order to organize the traditional industries and artisans for their growth and long term sustainability. The scheme stipulates **Coir Board** as the Nodal Agency for coir clusters.

The scheme specifies the following institutional arrangement at the operational level:

- a Special Purpose Vehicle (SPV) be formed to develop and manage the cluster
- an Implementing Agency (IA) is appointed to undertake scheme implementation
- a Technical Agency (TA) is designated to assist and guide the scheme implementation

Andaman Coir Cluster is approved under the scheme. **M/s.Andaman Coir Cluster Cooperative Society Limited**, having administrative office at Near Solai Candle Works, Cari Road, Bathubasthi, Garacharma Post, South Andaman - 744105, is the Special Purpose Vehicle (SPV) of the Cluster. **M/s.Yuvasakthi** is the Implementing agency of the cluster and **M/s.ITCOT Consultancy and Services Limited** is the designated Technical agency for the cluster.

The scheme envisages establishment of upgraded production infrastructure, as the Common Facility Center (CFC), for the manufacturing of coir products and stipulates the building construction and machinery procurement for the establishment of CFC should adhere the General Financial Rules (GFR) of Government of India. Accordingly, the tender procedures are being undertaken for the construction of CFC building works and procurement of machineries.

M/s.Andaman Coir Cluster Cooperative Society Limited, the Special Purpose Vehicle (SPV) of Andaman Coir Cluster, having the administrative office at Near Solai Candle Works, Cari Road, Bathubasthi, Garacharma Post, South Andaman – 744105 propose to establish a Common Facility Centre (CFC) at Bednobad Village, Port Blair Tehsil, South Andaman with the financial assistance from Government of India under SFURTI.

In this context, on behalf of SPV, **M/s.Yuvasakthi**, the Implementing Agency (IA) of Andaman Coir Cluster having administrative office at Near IACT Computer Education, MG Road, Junglighat (Post), Port Blair, South Andaman – 744 103, invites sealed tenders from Civil contractors in “Two Cover System” for the construction of industrial work shed buildings and amenities for the Common Facility Center for Andaman Coir Cluster through transparent bidding process. The Tender notification has been published fixing the date of opening of tender as 28.02.2020 at 03.00 PM.

2.	SCOPE OF WORK																
	<p>a) The successful tenderer should undertake construction of industrial work shed buildings and amenities at Bednobad Village, Port Blair Tehsil, South Andaman as per the drawings and Estimate/Bill of Quantity (BoQ) given in Annexure-I.</p> <p>b) The successful tenderer should complete the construction of industrial work shed buildings and amenities within 120 days from the date of receipt of Work Order. The time line for the cumulative percentage of work to be completed based on the value of work shall be as given below:</p> <table border="1" style="margin-left: auto; margin-right: auto;"> <thead> <tr> <th style="text-align: center;">Days</th> <th style="text-align: center;">Percentage of work to be completed</th> </tr> </thead> <tbody> <tr> <td style="text-align: center;">1st 30 days</td> <td style="text-align: center;">Min. 20% of total contract value</td> </tr> <tr> <td style="text-align: center;">2nd 30 days</td> <td style="text-align: center;">Min. 50% of total contract value</td> </tr> <tr> <td style="text-align: center;">3rd 30 days</td> <td style="text-align: center;">Min. 80% of total contract value</td> </tr> <tr> <td style="text-align: center;">4th 30 days</td> <td style="text-align: center;">100% of total contract value</td> </tr> </tbody> </table>		Days	Percentage of work to be completed	1 st 30 days	Min. 20% of total contract value	2 nd 30 days	Min. 50% of total contract value	3 rd 30 days	Min. 80% of total contract value	4 th 30 days	100% of total contract value					
Days	Percentage of work to be completed																
1 st 30 days	Min. 20% of total contract value																
2 nd 30 days	Min. 50% of total contract value																
3 rd 30 days	Min. 80% of total contract value																
4 th 30 days	100% of total contract value																
3.	QUALIFICATION CRITERIA																
	<table border="1" style="width: 100%; border-collapse: collapse;"> <thead> <tr> <th style="text-align: center;">Clause</th> <th style="text-align: center;">Qualification Criteria</th> <th style="text-align: center;">Supporting Document</th> </tr> </thead> <tbody> <tr> <td style="text-align: center;">3(a)</td> <td>The tenderer should be a registered legal entity.</td> <td> (i) In case of Private / Public Limited Companies, <ul style="list-style-type: none"> • Copy of Incorporation Certificate issued by the Registrar of Companies • Copy of Memorandum and Articles of Association (ii) In case of Partnership Firm, <ul style="list-style-type: none"> • Registered Partnership deed (iii) In case of Proprietorship Concern, <ul style="list-style-type: none"> • Copy of Udyog Aadhaar/ GST Registration Certificate / PAN Card. </td> </tr> <tr> <td style="text-align: center;">3(b)</td> <td>The tenderer should be an eligible Civil contractor</td> <td> (i) Valid Registration Certificate from PWD / CPWD / Highways dept. (ii) Valid registration of GST </td> </tr> <tr> <td style="text-align: center;">3(c)</td> <td>The tenderer should have at least 3 years of experience (as on 31st January 2020) as Civil contractor.</td> <td> (i) Work orders issued by clients (ii) Performance certificate issued by clients (iii) List of construction works executed in last 3 years as per Annexure-V </td> </tr> <tr> <td style="text-align: center;">3(d)</td> <td>The tenderer should have been awarded and successfully completed at least three works of</td> <td> (i) Work orders issued by clients (ii) Performance certificate issued by clients </td> </tr> </tbody> </table>		Clause	Qualification Criteria	Supporting Document	3(a)	The tenderer should be a registered legal entity.	(i) In case of Private / Public Limited Companies, <ul style="list-style-type: none"> • Copy of Incorporation Certificate issued by the Registrar of Companies • Copy of Memorandum and Articles of Association (ii) In case of Partnership Firm, <ul style="list-style-type: none"> • Registered Partnership deed (iii) In case of Proprietorship Concern, <ul style="list-style-type: none"> • Copy of Udyog Aadhaar/ GST Registration Certificate / PAN Card. 	3(b)	The tenderer should be an eligible Civil contractor	(i) Valid Registration Certificate from PWD / CPWD / Highways dept. (ii) Valid registration of GST	3(c)	The tenderer should have at least 3 years of experience (as on 31 st January 2020) as Civil contractor.	(i) Work orders issued by clients (ii) Performance certificate issued by clients (iii) List of construction works executed in last 3 years as per Annexure-V	3(d)	The tenderer should have been awarded and successfully completed at least three works of	(i) Work orders issued by clients (ii) Performance certificate issued by clients
Clause	Qualification Criteria	Supporting Document															
3(a)	The tenderer should be a registered legal entity.	(i) In case of Private / Public Limited Companies, <ul style="list-style-type: none"> • Copy of Incorporation Certificate issued by the Registrar of Companies • Copy of Memorandum and Articles of Association (ii) In case of Partnership Firm, <ul style="list-style-type: none"> • Registered Partnership deed (iii) In case of Proprietorship Concern, <ul style="list-style-type: none"> • Copy of Udyog Aadhaar/ GST Registration Certificate / PAN Card. 															
3(b)	The tenderer should be an eligible Civil contractor	(i) Valid Registration Certificate from PWD / CPWD / Highways dept. (ii) Valid registration of GST															
3(c)	The tenderer should have at least 3 years of experience (as on 31 st January 2020) as Civil contractor.	(i) Work orders issued by clients (ii) Performance certificate issued by clients (iii) List of construction works executed in last 3 years as per Annexure-V															
3(d)	The tenderer should have been awarded and successfully completed at least three works of	(i) Work orders issued by clients (ii) Performance certificate issued by clients															

	similar nature in the last 3 years (as on 31 st January 2020).	
3(e)	The tenderer should have reported a minimum Average Annual Turnover of Rs.40.00 lakhs in the last three consecutive financial years i.e. 2016-17, 2017-18 and 2018-19.	(i) The average annual turnover statement duly certified by Chartered Accountant as per Annexure IV (ii) The Annual Report/ certified copies of Balance Sheet, Profit & Loss statement along with schedules for the last 3 consecutive financial years
3(f)	The tenderer should not have been blacklisted for supply of any items or services by any Government departments/agency	The declaration form as per Annexure VI should be enclosed.

4. LANGUAGE OF THE TENDER

The Tender prepared by the tenderer as well as all correspondences and documents relating to the Tender shall be in English language only. If the supporting documents are in a language other than English/Tamil, the notarized translated English version of the documents should also be enclosed.

5. PURCHASE OF TENDER DOCUMENTS

- a) The tender document shall be downloaded from **www.coirboard.gov.in** or **www.itcot.com** at free of cost. The tenderer should give a declaration for not having tampered the Tender document downloaded from Internet (as per Annexure VII).
- b) The tender document can be downloaded from 05.02.2020 to 27.02.2020.

6. PREBID MEETING

There will be a pre-bid meeting on 17.02.2020 at 11.00 am in the office of **M/s.Yuvasakthi, Near IACT Computer Education, MG Road, Junglighat (Post), Port Blair, South Andaman – 744 103** during which the prospective tenderers can get clarifications about the tender. The tenderers shall send their queries in writing if any so as to reach IA at least two days prior to the pre-bid meeting date. The tenderers are advised to check **www.coirboard.gov.in** or **www.itcot.com** for up-to-date information like change in date / venue etc., of pre-bid meeting as IA may not be able to identify and communicate with the prospective bidders at this stage. Non attending of pre-bid meeting is not a disqualification.

7.	CLARIFICATION ON THE TENDER DOCUMENT
<p>The tenderers may ask for queries in any of the clauses in the tender document before 48 hours of the opening of the tender. Such queries may be sent in writing to “M/s.Yuvasakthi, Near IACT Computer Education, MG Road, Junglighat (Post), Port Blair, South Andaman – 744 103” or by e-mail to ia.yuvasakthi@gmail.com. IA will upload the clarification on www.coirboard.gov.in or www.itcot.com. It is binding on the part of tenderers to check the above said websites for any amendments or clarifications posted during the entire tender process.</p>	
8.	AMENDMENT OF TENDER DOCUMENT
<p>IA whether on its own initiative or as a result of a query, suggestion or comment of an Applicant or a Respondent, may modify the tender document by issuing an addendum or a corrigendum at any time before the opening of the tender, with the concurrence of the tender committee. Any such addendum or corrigendum will be uploaded on www.coirboard.gov.in or www.itcot.com and the same will be binding on all Applicants or Respondents or Tenderers, as the case may be.</p>	
9.	AUTHORISATION OF THE TENDERER
<p>The Tender should be signed on each page by the tenderer or by the person who is duly authorized for the same by the tenderer.</p>	
10.	PRE-VISIT OF SITE
<p>The tenderer, on his/her own responsibility, risk and cost, is advised to visit and examine the site of works (Bednabad Village, Port Blair Tehsil, South Andaman) and its surroundings and obtain all information that may be necessary for preparing the bid and entering into a contract for the work(s) as mentioned in the Annexure (I).</p>	
11.	SPECIFIC INSTRUCTIONS TO BIDDERS / CONTRACTORS FOR QUOTING OF RATES
<p>(a) The contractors are requested to read the detailed specification and quote the rates clearly in the Price bid. Quoting the rates in the Price bid will only be taken up for comparison and shall be final.</p> <p>(b) The tenders invited are based on item wise rates mentioned in the estimate of works/BoQ. Any lumpsum deductions or increase or rebate offered either in the tender or in the covering letter or at any portion of the tender will be ignored and only the rates</p>	

offered in the Price bid alone will be taken as valid rates and taken up for tender comparison. Rates or Lumpsum amounts for items not called for shall not be included in the tender. Any alteration made by tenderer in the contract form, the conditions to Contract, the drawings, specification, or quantities accompanying the same will not be recognized and if any such alterations are made the tender will be void.

- (c) The tenderer / contractor will make his/her/their own arrangements to procure and use ISI Brand Cement and ISI Brand steel required for the work.
- (d) It should be clearly understood that the rate quoted by the tenderer / contractor is inclusive of incidental charges such as conveyance, loading, unloading, stacking at site and testing charges etc., complete.
- (e) The tenderer / contractor will produce test certificate obtained from any one of the Govt. institutions for cement and steel brought to site. And only when the test results confirm to the ISI specification they will be allowed to be used in the works.
- (f) The tenderer / Contractor should strictly follow above instructions without fail.

12. SUBMISSION OF TENDER IN TWO COVER SYSTEM

- (a) Every page of the terms and conditions of the tender document should be signed and enclosed with the tender, in token of having accepted the tender conditions. Failing which the tender will be rejected summarily.
- (b) Tenders should be submitted in two parts:
 - i. Part I will cover technical bid and
 - ii. Part II will cover price bid
- (c) Tenderers should ensure submission of all documents pertaining to Part-I and Part II proposals separately as per the Check list given in Annexure -X.
- (d) Tenderers are requested to place Part I and Part II documents in separate sealed covers. Part I cover to be superscripted as “**Part I – Technical bid**” and Part II cover to be superscripted as “**Part II – Price bid**” respectively, mentioning the name and address of the Tenderer in each of the both covers. These two sealed covers (Part I and Part II) must be placed in a single outer cover superscripted as “**Tender for the construction of work shed buildings and amenities for Andaman Coir Cluster**” and addressed to “**M/s.Yuvasakthi, Near IACT Computer Education, MG Road, Junglighat (Post), Port Blair, South Andaman – 744 103**” mentioning the name and address of the Tenderer in the outer cover. **Tenders shall be submitted in sealed cover and unsealed tenders would summarily be rejected.**
- (e) Tenders should be dropped only in the tender box kept at the office of “M/s.Yuvasakthi, Near IACT Computer Education, MG Road, Junglighat (Post), Port Blair, South Andaman – 744 103” on or before 02.00 PM on 28.02.2020. Tenders will not be received by hand.

(f) Alternatively, the tenders can be submitted through registered post so as to reach the above address on or before 02.00 PM on 28.02.2020. Tenders received after the specified time will not be considered and IA will not be liable or responsible for any postal delays.

(g) A tender once submitted shall not be permitted to be altered or amended.

13. EARNEST MONEY DEPOSIT

(a) The Tender should be accompanied by an Earnest Money Deposit (EMD) to the value of Rs.1,50,000 /- (Rupees One lakh Fifty thousand only) in the form of Account Payee Demand Draft drawn on any Indian Nationalized/Scheduled Commercial Bank in favour of “HI Account Andaman Coir Cluster”, payable at Port Blair. The EMD in any other form will not be accepted. The Earnest Money Deposit will be returned to the unsuccessful tenderers at the earliest on the expiry of final bid validity and latest on or before the 30th day of the award of contract.

(b) The Earnest Money Deposit will be retained in the case of successful tenderer and it will not earn any interest and will be dealt with, as provided in the terms and conditions of the tender.

(c) Any request of the tenderer, under any circumstances claiming exemption from payment of EMD will be rejected and their Part II price offer will not be opened.

(d) If the tenderer emerges as the successful bidder and after subsequent issuance of letter of acceptance by the IA, failure to sign the agreement, to remit the Security Deposit or to execute the contract as per tender conditions, will result in the forfeiture of the EMD amount remitted.

14. VALIDITY

(a) The rate quoted in the Tender should be valid for the acceptance by the IA for a minimum period of 90 days from the date of opening of the Tender.

(b) The accepted rate of the successful tenderer is valid till the entire contract is fully completed. Escalation in the rates will not be entertained under any circumstances.

15. OPENING AND EVALUATION OF THE TENDER

(a) The tender box will be closed at 2.00 PM as per the office clock on 28.02.2020 and the received tenders in the tender box will only be opened. Tenders received after specified date and time will not be accepted. The Tender will be opened by the Tender committee at 03.00 PM on the same day in the presence of the available Tenderers/ representatives of the Tenderers who choose to be present. The Tenderers or their authorized agents are allowed to be present at the time of opening of the tenders.

- (b) Tender Committee will inform the attested and unattested corrections, before the Tenderers and sign all such corrections in the presence of the Tenderers. If any of the Tenderers or agents not present then, in such cases the Committee will open the tender of the absentee Tenderer and take out the unattested corrections and communicate it to them. The absentee Tenderer should accept the corrections without any question whatsoever.
- (c) If the date fixed for opening of the tender happens to be a Government holiday, the sealed tenders will be received up to 02.00 PM on the next working day and opened at 03.00 PM on the same day.
- (d) The Technical bid will be evaluated by the tender committee in terms of the qualification Criteria. The committee reserves the right to disqualify any of the tender in case the Committee is not satisfied with the documents furnished.
- (e) After the completion of evaluation of technical bids, the tenderers declared as qualified by the Committee, will be informed the date of opening of Price bid (Part II).

16. PRICE OFFER

- (a) The Price bid should be kept only in the Part II cover.
- (b) The price bid should be prepared as per Annexure-IX.
- (c) The price should be neatly and legibly written both in figures and words.
- (d) In case of discrepancy between the prices quoted in words and figures lower of the two shall be considered.
- (e) If a bidder quotes NIL charges/consideration, the bid shall be treated as unresponsive and will not be considered.
- (f) Part-II bid should not contain any commercial conditions. Variation in the commercial terms and conditions of the tender will not be accepted.

17. EVALUATION OF THE PRICE

- (a) The Tender committee will examine for complete, properly signed and error-free nature of the Price bid (Part II)
- (b) The comparison of the rates offered shall be based on the total all inclusive rates offered (i.e. sum of all inclusive rate offered for all the tendered items).

18.	AWARD OF CONTRACT
<p>(a) The Tenderer who has quoted lowest price (L1) will be issued the 'Letter of Acceptance' by the Implementing Agency.</p> <p>(b) In unavoidable circumstances, such as receipt of very limited bids or the proposal prices are substantially higher than the market value / updated cost estimate or available budget, the committee may decide upon resorting to Negotiation with the lowest evaluated responsive bidder. In such cases, the Tenderer who has quoted lowest price (L1) will be invited for negotiations and after finalizing the negotiated rate, Letter of Acceptance will be issued.</p>	
19.	SECURITY DEPOSIT
<p>(a) On receipt of the Letter of Acceptance from IA, the successful tenderer should remit a Security Deposit (SD) of 5% of the value of the contract in the form of Account payee Demand Draft from any Indian Nationalized/Scheduled Commercial Bank or irrevocable Bank Guarantee with a validity period of one year in favour of "HI Account Andaman Coir Cluster", payable at Port Blair, within 10 (Ten) working days from the date of receipt of letter of acceptance. The EMD shall be adjusted with the Security Deposit.</p> <p>(b) Any other amount pending with IA will not be adjusted under any circumstances, against the Security Deposit if so requested.</p> <p>(c) If the Security Deposit amount is not paid within the time specified, the EMD remitted by the tenderer shall be forfeited, besides cancelling the communication of acceptance of the Tender.</p> <p>(d) Security Deposit amount remitted will not earn any interest.</p>	
20.	AGREEMENT
<p>The successful tenderer should execute an agreement as may be drawn up to suit the conditions on a non-judicial stamp paper of value, as prescribed in law on the date of remittance of Security Deposit and shall pay for all stamps and legal expenses incidental thereto. In the event of failure to execute the agreement, within the time prescribed, the EMD/SD amount remitted by the tenderer will be forfeited besides cancelling the Tender.</p>	
21.	ISSUE OF WORK ORDER
<p>After payment of Security Deposit and successful execution of the agreement, Work Order will be released within 10 days by the IA. The successful tenderer should complete the</p>	

construction of industrial work shed buildings and amenities within 120 days from the date of receipt of Work Order.

22. DEFECT IDENTIFICATION AND IT'S RECTIFICATIONS

- (a) Defect Liability period shall be 6 months from the date of the completion of work. Any defect arising in the work in guarantee period due to faulty workmanship and faulty materials should be rectified by contractor at his own cost.
- (b) Any deficiency in concreting such as cracking, excessive honeycombing, exposure of reinforcement or other fault which entail replacement of the defective part by fresh concrete and whatsoever remedy reasonable required without hampering the structural safely and architectural concept, all at the cost of contractor.
- (c) The successful tenderer should submit bank guarantee equivalent to 10% of the total value of contract valid for 6 months towards Defect Liability.

23. EMPLOYMENT OF TECHNICAL ASSISTANTS

- (a) The tenderer shall employ qualified technical persons at his cost to supervise the work and the tenderer should ensure the presence of the technical persons at the site of work during working hours, monitoring all items of works and paying extra attention to such works as may demand special attention.
- (b) A movement register should be opened and maintained for Technical persons employed by the Contractor. The Technical persons should note the arrival and the departure timings every day along with their initials in a register. Such Register should be produced during inspection of the Inspecting Officers (Tender committee members).

24. PAYMENT TERMS

- (a) **20% of the contract value** will be paid on completion of Foundation level works and submission of Stage level completion certificate by a Chartered Engineer, based on the inspection report by Tender Committee.
- (b) **40% of the contract value** will be paid on completion of roof level works and submission of Stage level completion certificate by a Chartered Engineer, based on the inspection report by Tender Committee.
- (c) **The balance 40% and SD** will be released only after satisfactory completion of the entire contract based on the inspection report by Tender Committee and submission of Chartered Engineer's work completion & valuation certificate and bank guarantee equivalent to 10% of the total value of contract valid for 6 months towards Defect Liability.

(d) IA also reserves the right to recover any dues from the tenderer, which is found on later date, during audit/excess payment, after final settlement is made to them. The successful tenderer is liable to pay such dues to the IA immediately on demand, without raising any dispute/protest.

25. PENALTY

- (a) Failure to execute the entire contract within 120 days from the date of issue of work order will attract a penalty of 1% per week, on the full value of the contract upto a maximum of 5%. Delays beyond that period will be viewed as violation of the contract terms and will be dealt accordingly.
- (b) Implementing agency reserves the right to inspect the site at any point of time during the contract period to ensure the progress and quality of work carried out. During the inspection, if any discrepancies found in the quality of work / material used, the IA, with the approval of the tender committee, reserves the right to order for any rework(s) / replace any item(s) of material, as the case may be, in order to ensure the quality of work / progress as per the contract terms.
- (c) All the materials used for construction shall be first use, new, high quality material. Old or Used materials will not be accepted and if found, the decision of Committee, either for rework / replace / deduction in payment shall be binding on the contractor.
- (d) Any delay on the part of IA should be intimated and sorted out immediately without affecting the progress of works.

26. TERMINATION OF CONTRACT

IA reserves the right to terminate the contract at any time during the validity period on account of non-fulfillment of contract or for any of the reasons.

27. GENERAL CONDITIONS

- (a) Conditional tender in any form will not be accepted.
- (b) Any notice regarding any matters, to the contractor shall deemed to be sufficiently served, if given in writing to his usual or last known place of business.
- (c) Tender committee reserves the right to relax or waive or amend any of the tender conditions.
- (d) The successful tenderer shall not outsource/off load either full or part of the work to any other agency / individual.

(e) If the performance of the tenderer is not as per the schedule, then tender committee reserves the right to cancel / reallocate full or part of the contract, at any stage of the contract execution.

28. ARBITRATION

(a) In case of any dispute in the tender, including interpretation, if any, on the clauses of the tender or the agreement to be executed, the matter shall be referred by IA / Tenderer to an Arbitrator to be appointed by the Parties hereto by mutual agreement. If no such Arbitrator could be appointed by mutual consent, the matter may then be referred to the Chairman, Coir Board for nominating an Arbitrator, the Arbitration proceedings being governed by the Arbitration and Conciliation (Amendment) Act 2015.

(b) The venue of the Arbitration shall be at the Coir Board Sub Regional Office Annex Building, Udyog Parisar, Opp. Departmental Workshop, Middle Point, Port Blair – 744 101. The decision of the Arbitrator shall be final and binding on both the parties to the Arbitration.

(c) The Arbitrator may with the mutual consent of the parties, extend the time for making the award. The award to be passed by the Arbitrator is enforceable in the court at Andaman only.

29. JURISDICTION OF THE COURT

Any dispute arising out of non-fulfillment of any of the terms and conditions of this Agreement or any other dispute arising out of the arbitration award will be subject to the jurisdiction of the Courts in the City of Andaman only.

We agree to the above terms and conditions.

SIGNATURE OF THE TENDERER:

DATE:

NAME IN BLOCK LETTERS:

DESIGNATION:

ADDRESS:

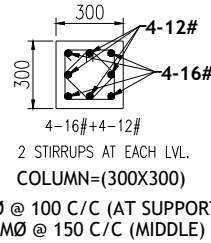
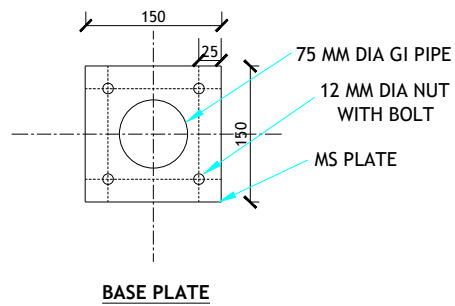

DETAIL OF COLUMN

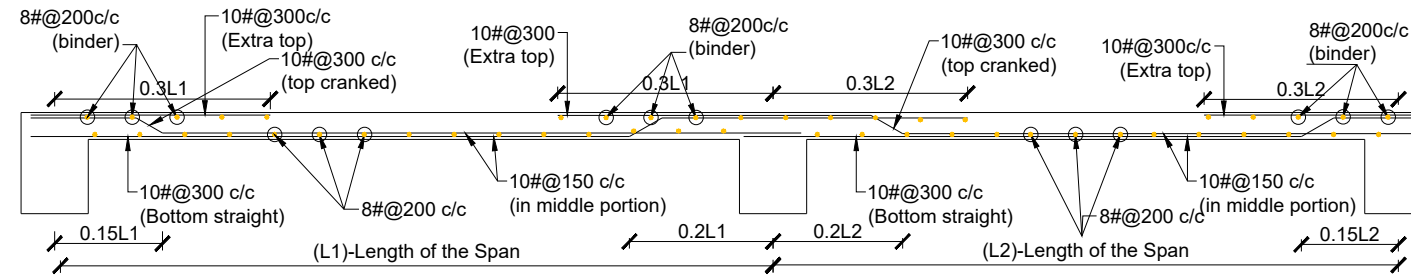

SLAB DETAILS(S)=125mm thk.
SCALE 1:25

COVER DEFINITION

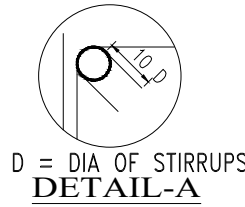
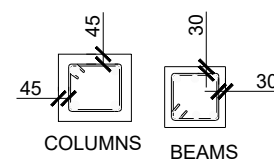

D = DIA OF STIRRUPS
DETAIL-A

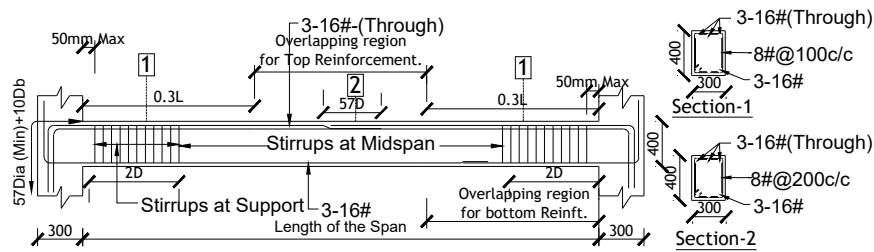

DETAILS OF BEAMS-B1
SCALE 1:50

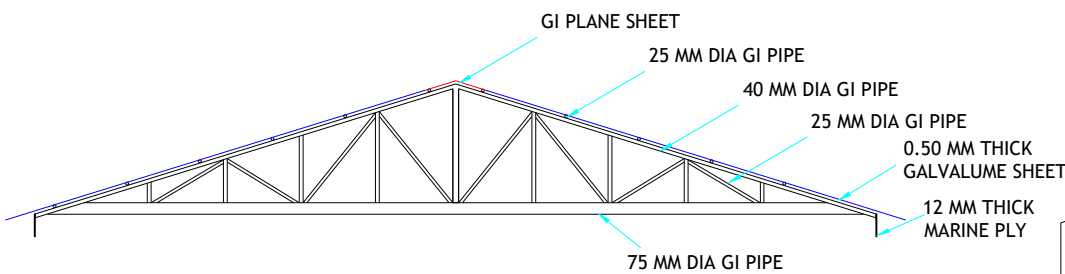

DETAILS OF TRUSS

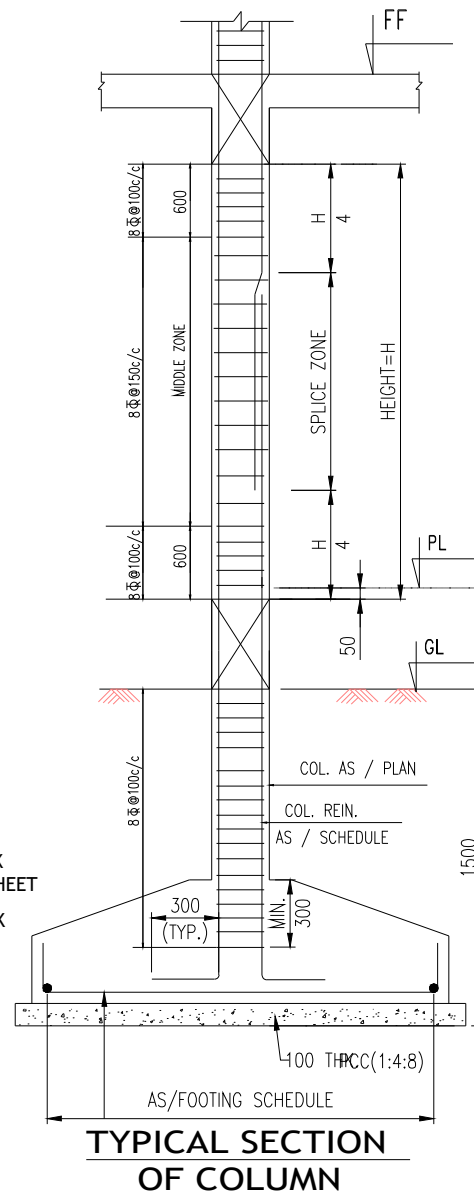

TYPICAL SECTION OF COLUMN

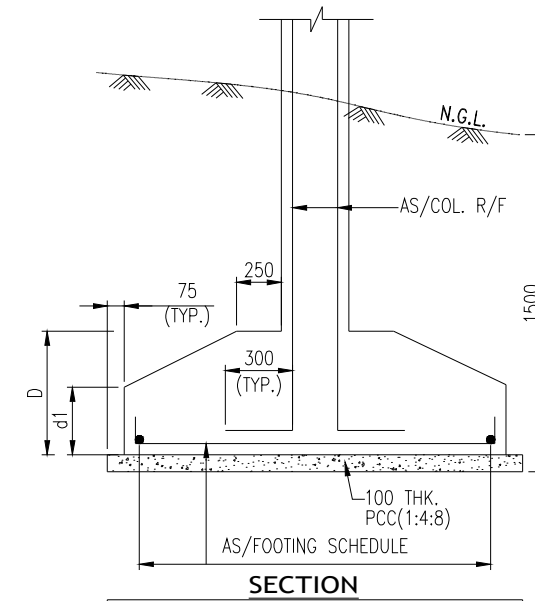

SECTION

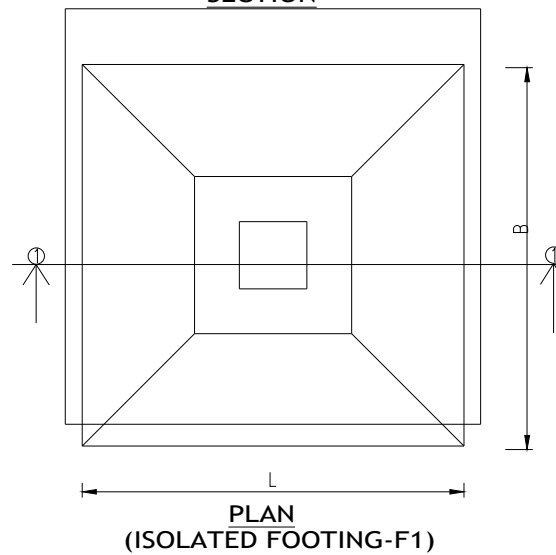

PLAN (ISOLATED FOOTING-F1)

FOOTING SCHEDULE

TYPE	SIZE		D1	D2	R/F AT BOTT. B/W	
	L	B				
F1	1000	1000	200	350	10*150c/c	BOTH WAYS

GENERAL NOTES

- ALL DIMENSIONS ARE IN MM UNLESS AND UNTIL SPECIFIED.
- WRITTEN DIMENSION SHOULD BE FOLLOWED AND NO DIMENSION SHALL BE SCALE FROM THE DRAWING.
- GRADE OF THE CONCRETE MIX SHALL BE M-20 CONFORMING TO IS :456-2000.
- REINFORCEMENT SHALL BE HIGH STRENGTH DEFORMED BARS OF GRADE Fe 415 CONFORMING TO IS :1786-1985.
- THE DESIGN INCORPORATES THE PROVISIONS CONTAINED IN IS: 13920-1993 FOR DESIGN OF EARTHQUAKE RESISTANT.
- STRUCTURES USING SEISMIC CO-EFFICIENT METHOD.
- THE CLEAR COVER FOR MAIN REINFORCEMENT UNLESS OTHERWISE SPECIFIED SHALL BE 30MM FOR BEAM, 40MM FOR COLUMN, 15MM FOR SLAB & 75MM FOR FOOTING.
- THICKNESS OF THE FLOOR SLAB IS 120MM THROUGHOUT.
- THE ANCHORAGE LENGTH OF THE BAR IS TO BE MAINTAINED AS 57d FOR TENSION AND 57d FOR COMPRESSION , WHERE d IS THE DIA. OF THE BAR.
- CORNER REINFORCEMENT SHALL BE PROVIDED WHERE SHOWN ON THE PLAN.
- STANDARD HOOKS AND LAPS SHALL BE PROVIDED WHEREVER NECESSARY.
- STIRRUPS FOR MAIN BEAM SUPPORTING SECONDARY BEAMS MAY BE UNIFORM THROUGHOUT AND AS PER THE STIRRUPS SPACING PROVIDED AT THE ENDS SUPPORTS.
- ALL RCC WORKS SHALL BE ADEQUATELY VIBRATED DURING CASTING.
- STRUCTURAL DRAWING SHOULD BE STRICTLY FOLLOWED WITH RESPECT TO ARCHITECTURAL DRAWING.
- S.B.C OF PROPOSED SITE IS ASSUMED 100 TON/M SQUARE (APPROX.) SHOULD BE CHECKED BEFORE EXECUTION.

NAME OF WORK

PROPOSED CONSTRUCTION OF COIR INDUSTRY AT BEDNOBAD VILLAGE.

CLIENT :

STRUCTURAL DRAWING

SIGNATURE OF ARCHITECT/ ENGINEER

SIGNATURE OF OWNER

Coir Yarn Spinning Workshed

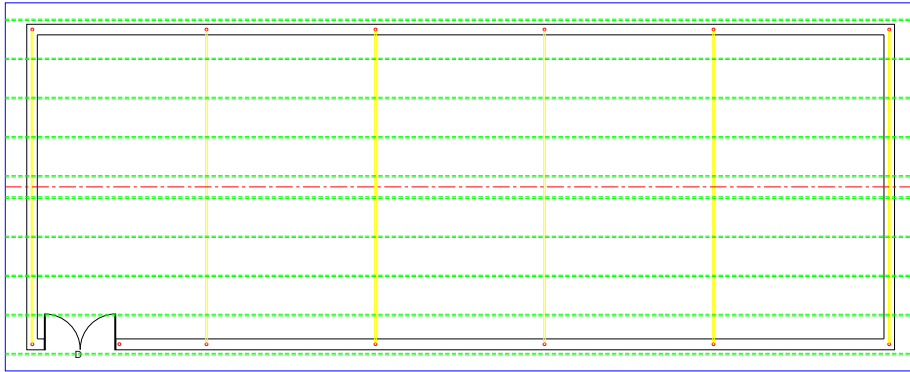

PLAN AT TRUSS LEVEL

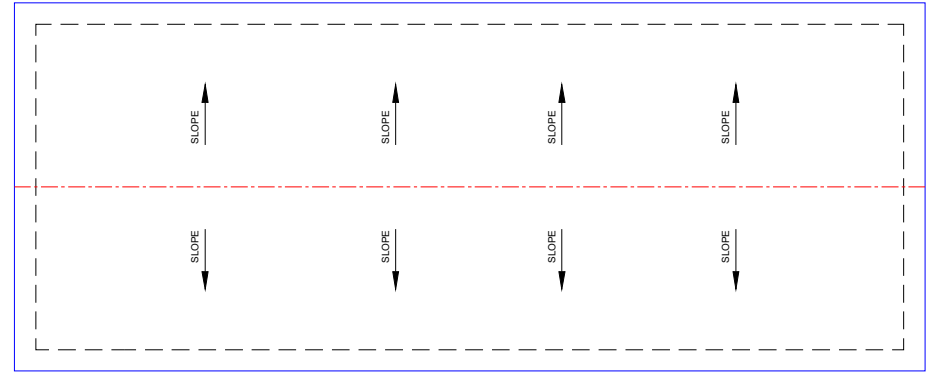

PLAN AT ROOF LEVEL

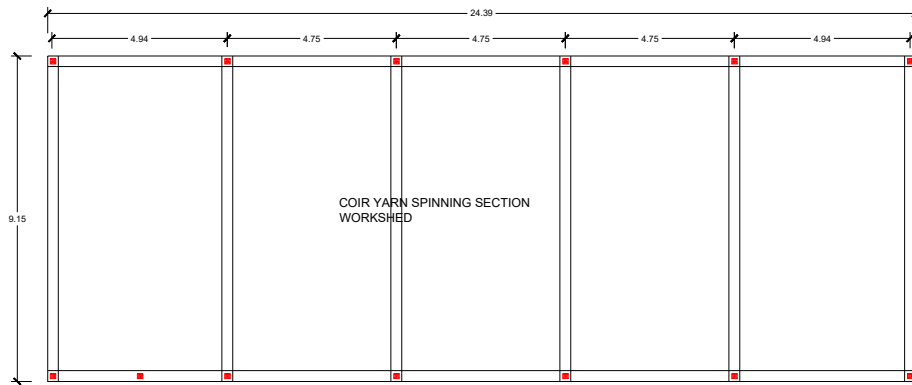

PLAN AT PLINTH BEAM LEVEL

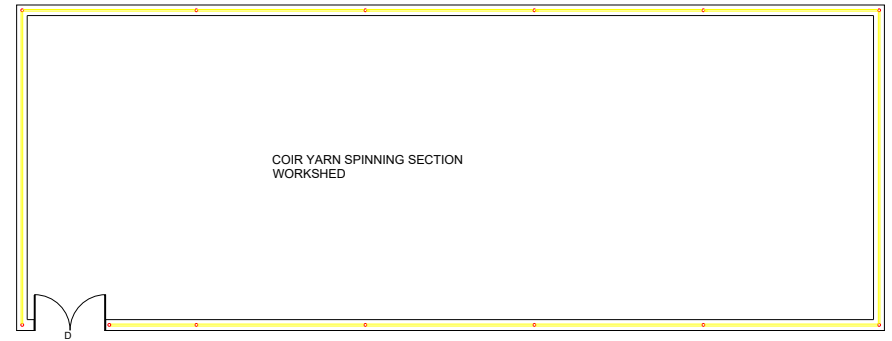

PLAN AT SILL LEVEL

Curled Coir workshed

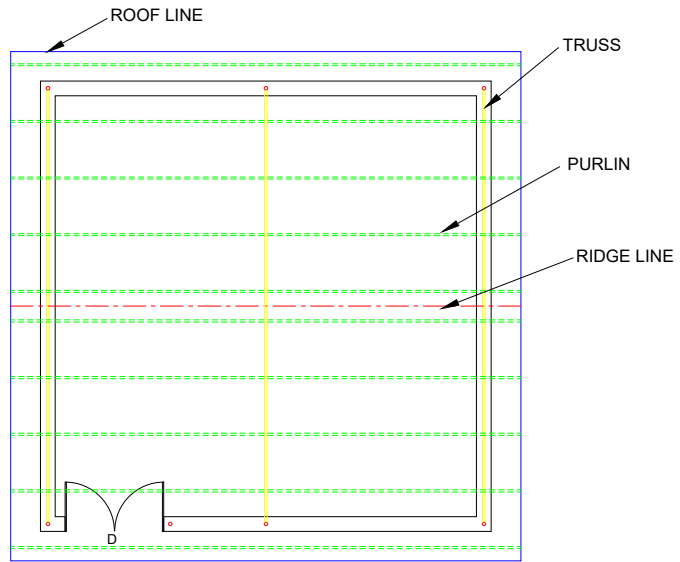

PLAN AT TRUSS LEVEL

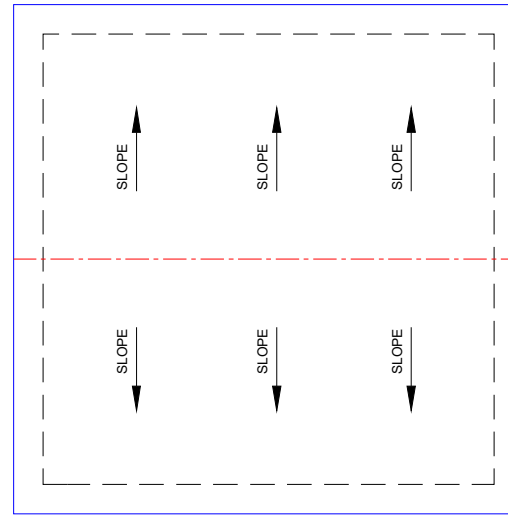

PLAN AT ROOF LEVEL

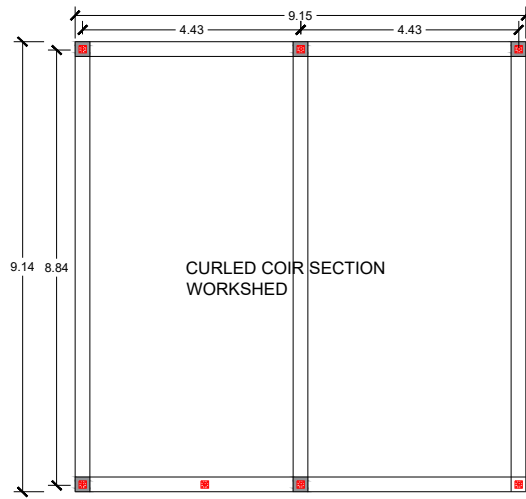

PLAN AT PLINTH BEAM LEVEL

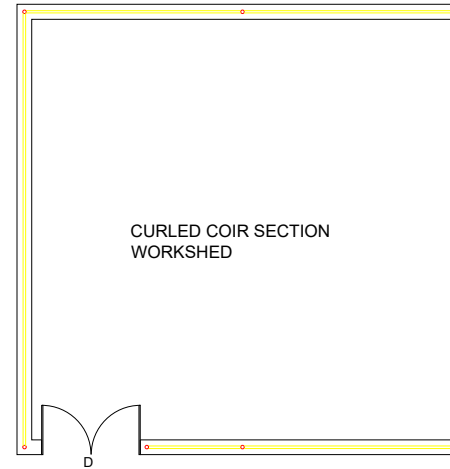

PLAN AT SILL LEVEL

Coir Fibre Extraction Workshed

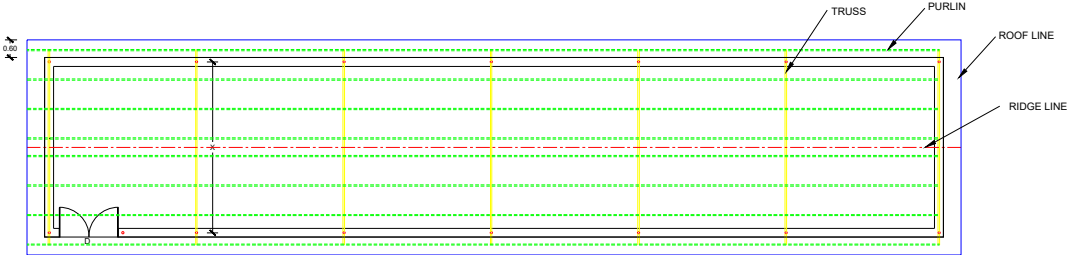

PLAN AT TRUSS LEVEL

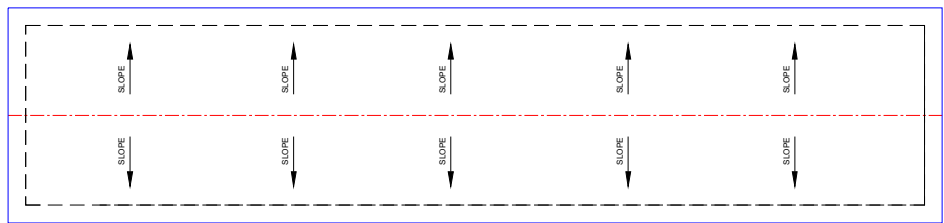

PLAN AT ROOF LEVEL

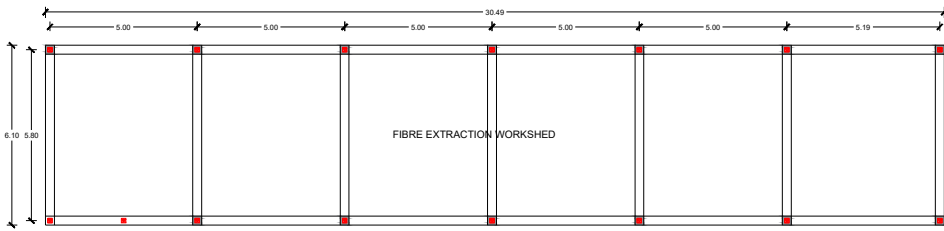

PLAN AT PLINTH BEAM LEVEL

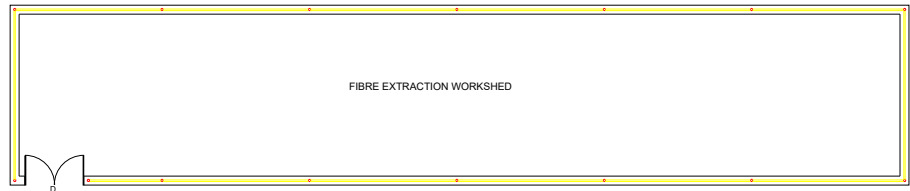

PLAN AT SILL LEVEL

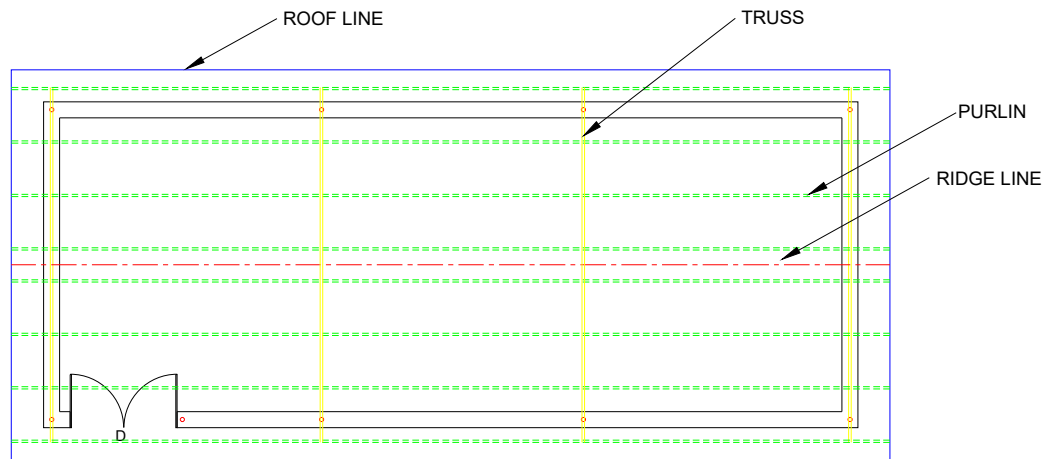

PLAN AT TRUSS LEVEL

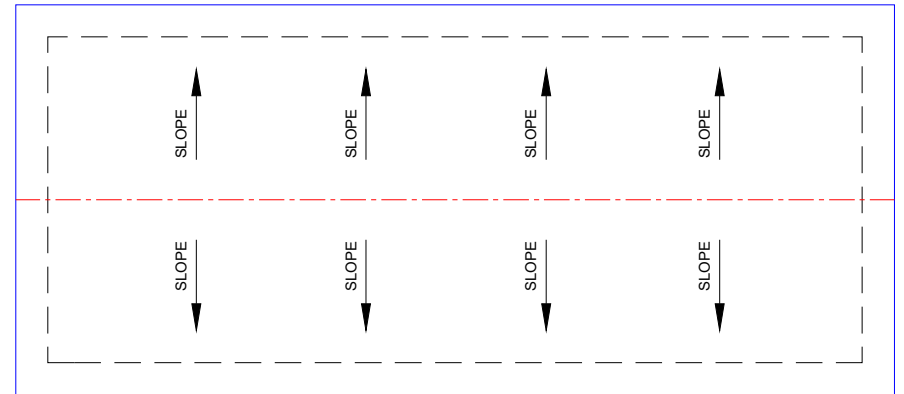

PLAN AT ROOF LEVEL

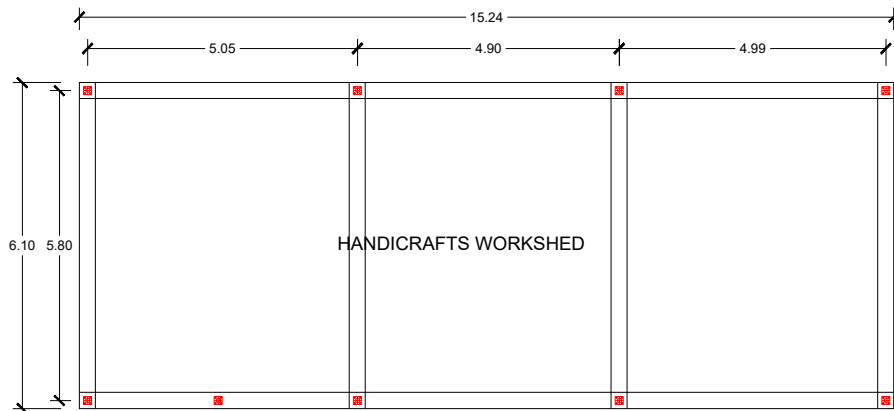

PLAN AT PLINTH BEAM LEVEL



PLAN AT SILL LEVEL

Drying Yard

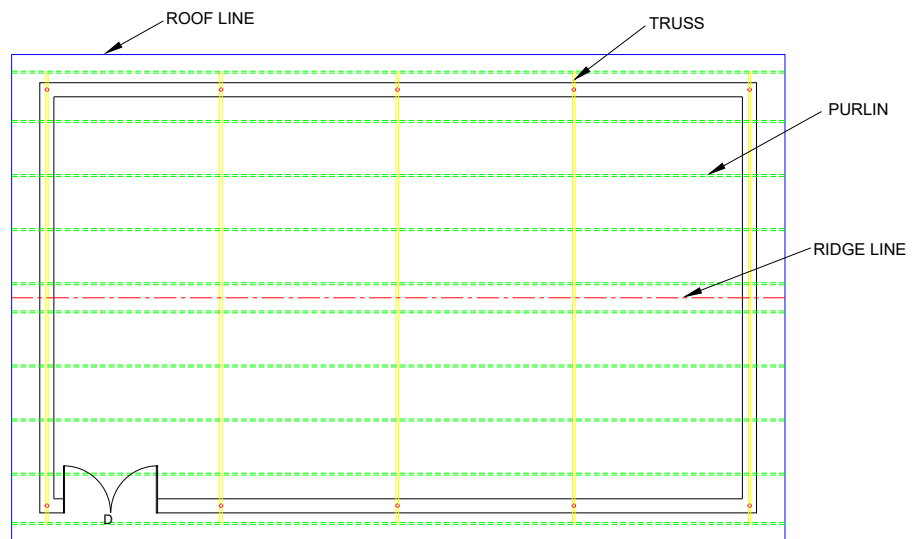

PLAN AT TRUSS LEVEL

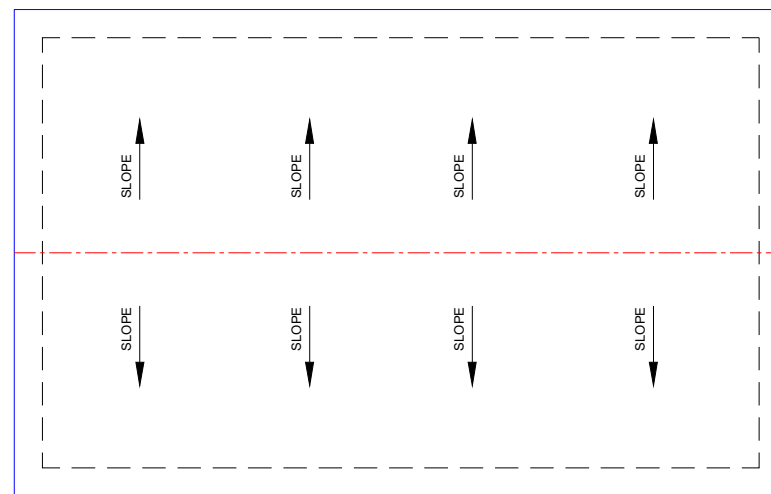

PLAN AT ROOF LEVEL

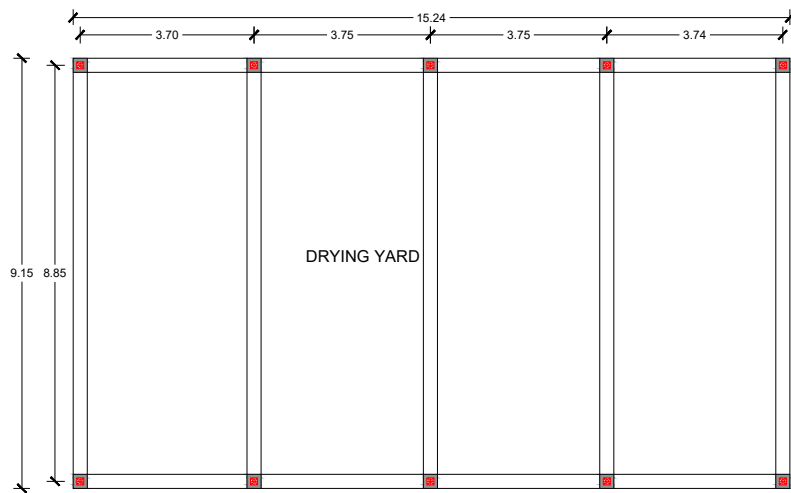

PLAN AT PLINTH BEAM LEVEL

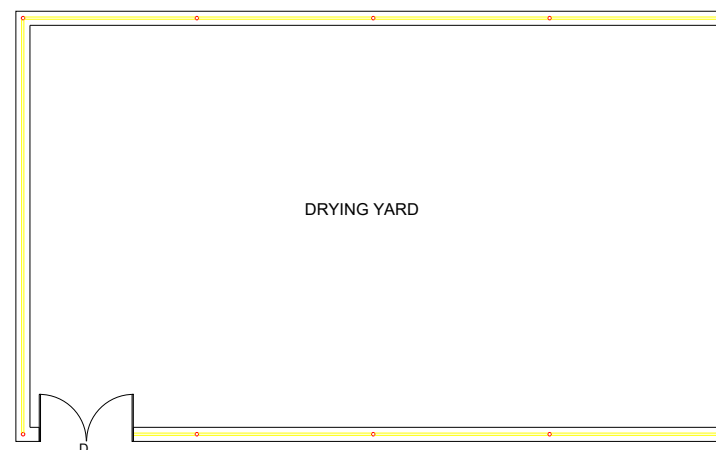

PLAN AT SILL LEVEL

S.No.	DESCRIPTION	NO.	L	B	H	QTY.	UNIT
1	Earth work excavation in foundation trenchers or drain not exceeding 1.5m width or 10 sqm on plan including dressing of sides and ramming of bottom lift upon 1.5 including getting out the excavated soil as directed within a lead of 50m. a)All kind of soil						
	FOUNDATION	12.00	1.00	1.00	1.00	12.00	CUB
	FOUNDATION	10.00	1.00	1.00	1.00	10.00	CUB
	FOUNDATION	10.00	1.00	1.00	1.00	10.00	CUB
	FOUNDATION	8.00	1.00	1.00	1.00	8.00	CUB
	FOUNDATION	14.00	1.00	1.00	1.00	14.00	CUB
	FOUNDATION	9.00	1.00	1.00	1.00	9.00	CUB
	FOUNDATION	6.00	1.00	1.00	1.00	6.00	CUB
	FOUNDATION	8.00	1.00	1.00	1.00	8.00	CUB
	FOUNDATION	4.00	1.00	1.00	1.00	4.00	CUB
	FOUNDATION	4.00	3.00	1.00	1.00	12.00	CUB
						93.00	CUB
2	Supplying and filling on plinth with local or pulverised sand under floor including watering, ramming consolidating and dressing complete						
	PLINTH BEAM	1.00	9.00	24.00	0.30	64.80	CUB
	PLINTH BEAM	1.00	9.00	18.30	0.30	49.41	CUB
	PLINTH BEAM	1.00	9.00	15.25	0.30	41.18	CUB
	PLINTH BEAM	1.00	6.10	15.25	0.30	27.91	CUB
	PLINTH BEAM	1.00	6.10	30.50	0.30	55.82	CUB
	PLINTH BEAM	1.00	7.60	6.10	0.30	13.91	CUB
	PLINTH BEAM	1.00	9.15	9.15	0.30	25.12	CUB
	PLINTH BEAM	1.00	9.15	6.10	0.30	16.74	CUB
	PLINTH BEAM	1.00	3.00	4.00	0.30	3.60	CUB
	PLINTH BEAM	3.00	3.00	3.00	0.30	8.10	CUB
						306.58	CUB
3	Providing and Laying position cement concrete of specified grade excluding the cost of centering and shuttering. All work upto plinth level.a)1:4:8(1 cement 4 Coarse sand: 8 graded stone aggregate 40mm nominal size.						
	FOUNDATION	12.00	1.00	1.00	0.10	1.20	CUB
	FLOORING	1.00	9.30	24.50	0.10	22.79	CUB
	FOUNDATION	10.00	1.00	1.00	0.10	1.00	CUB
	FLOORING	1.00	9.30	18.30	0.10	17.02	CUB
	FOUNDATION	10.00	1.00	1.00	0.10	1.00	CUB
	FLOORING	1.00	9.30	15.25	0.10	14.18	CUB
	FOUNDATION	8.00	1.00	1.00	0.10	0.80	CUB
	FLOORING	1.00	6.10	15.25	0.10	9.30	CUB
	FOUNDATION	14.00	1.00	1.00	0.10	1.40	CUB
	FLOORING	1.00	6.10	30.50	0.10	18.61	CUB
	FOUNDATION	9.00	1.00	1.00	0.10	0.90	CUB
	FLOORING	1.00	7.60	6.10	0.10	4.64	CUB
	FOUNDATION	6.00	1.00	1.00	0.10	0.60	CUB
	FLOORING	1.00	9.15	9.15	0.10	8.37	CUB
	FOUNDATION	8.00	1.00	1.00	0.10	0.80	CUB
	FLOORING	1.00	6.10	9.15	0.10	5.58	CUB
	FOUNDATION	4.00	1.00	1.00	0.10	0.40	CUB
	FLOORING	1.00	3.00	4.00	0.10	1.20	CUB
	FOUNDATION	3.00	1.00	1.00	0.10	0.30	CUB
	FLOORING	1.00	3.00	3.00	0.10	0.90	CUB
						110.98	CUB
4	Reinforced cement concrete work in foundation columns, beam, slab, landing, balconies, chajjis, stair excluding the cost of centering and shuttering and reinforcement with 1:1.5:3(1 cement: 1.5 Coarse sand : 3 graded stone aggregate 20mm nominal size)						
	FOUNDATION	12.00	1.00	1.00	0.25	3.00	CUB
	SHORT CULUMNS	12.00	0.30	0.30	1.00	1.08	CUB
	RCC BEAM	2.00	24.30	0.30	0.30	4.37	CUB
		2.00	9.15	0.30	0.30	1.65	CUB
	COLUMNS	12.00	0.30	0.30	1.00	1.08	CUB
	FOUNDATION	10.00	1.00	1.00	0.25	2.50	CUB
	SHORT CULUMNS	10.00	0.30	0.30	1.00	0.90	CUB
	RCC BEAM	2.00	18.30	0.30	0.30	3.29	CUB

		2.00	9.15	0.30	0.30	1.65	CUB
	COLUMNS	10.00	0.30	0.30	1.00	0.90	CUB
	FOUNDATION	10.00	1.00	1.00	0.25	2.50	CUB
	SHORT CULUMNS	10.00	0.30	0.30	1.00	0.90	CUB
	RCC BEAM	2.00	15.25	0.30	0.30	2.75	CUB
		2.00	9.15	0.30	0.30	1.65	CUB
	COLUMNS	10.00	0.30	0.30	1.00	0.90	CUB
	FOUNDATION	8.00	1.00	1.00	0.25	2.00	CUB
	SHORT CULUMNS	8.00	0.30	0.30	1.00	0.72	CUB
	RCC BEAM	2.00	15.25	0.30	0.30	2.75	CUB
		2.00	6.10	0.30	0.30	1.10	CUB
	COLUMNS	8.00	0.30	0.30	1.00	0.72	CUB
	FOUNDATION	14.00	1.00	1.00	0.25	3.50	CUB
	SHORT CULUMNS	14.00	0.30	0.30	1.00	1.26	CUB
		2.00	6.10	0.30	0.30	1.10	CUB
	COLUMNS	14.00	0.30	0.30	1.00	1.26	CUB
	FOUNDATION	9.00	1.00	1.00	0.25	2.25	CUB
	SHORT CULUMNS	9.00	0.30	0.30	1.00	0.81	CUB
	PLINTH PEAM	3.00	7.60	0.30	0.30	2.05	CUB
		3.00	6.10	0.30	0.30	1.65	CUB
	COLUMNS	9.00	0.30	0.30	3.00	2.43	CUB
	FLOOR BEAM	3.00	8.60	0.30	0.30	2.32	CUB
		3.00	8.10	0.30	0.30	2.19	CUB
		1.00	8.10	8.60	0.12	8.36	CUB
	FOUNDATION	6.00	1.00	1.00	0.25	1.50	CUB
	SHORT CULUMNS	6.00	0.30	0.30	1.00	0.54	CUB
	RCC BEAM	2.00	9.15	0.30	0.30	1.65	CUB
		2.00	9.15	0.30	0.30	1.65	CUB
	COLUMNS	6.00	0.30	0.30	1.00	0.54	CUB
	FOUNDATION	8.00	1.00	1.00	0.25	2.00	CUB
	SHORT CULUMNS	8.00	0.30	0.30	1.00	0.72	CUB
	RCC BEAM	2.00	9.15	0.30	0.30	1.65	CUB
		2.00	6.10	0.30	0.30	1.10	CUB
	COLUMNS	8.00	0.30	0.30	1.00	0.72	CUB
	FOUNDATION	4.00	1.00	1.00	0.25	1.00	CUB
	SHORT CULUMNS	4.00	0.30	0.30	1.00	0.36	CUB
	RCC BEAM	2.00	3.00	0.30	0.30	0.54	CUB
		2.00	4.00	0.30	0.30	0.72	CUB
	COLUMNS	4.00	0.30	0.30	1.00	0.36	CUB
	FOUNDATION	12.00	1.00	1.00	0.25	3.00	CUB
	SHORT CULUMNS	12.00	0.30	0.30	1.00	1.08	CUB
	RCC BEAM	6.00	3.00	0.30	0.30	1.62	CUB
		6.00	3.00	0.30	0.30	1.62	CUB
	COLUMNS	12.00	0.30	0.30	1.00	1.08	CUB
						89.01	CUB
5	Centring and shuttering including strutting, propping etc.foundation columns, beams, walls, suspended floor, landing, balconies, and cantilever etc.						
	FOUNDATION	12.00	1.00	0.25	4.00	12.00	SQM
	SHORT CULUMNS	12.00	0.30	1.00	4.00	14.40	SQM
	RCC BEAM	2.00	24.30	0.30	2.00	29.16	SQM
		2.00	9.15	0.30	2.00	10.98	SQM
	COLUMNS	12.00	0.30	1.00	4.00	14.40	SQM
	FOUNDATION	10.00	1.00	0.25	4.00	10.00	SQM
	SHORT CULUMNS	10.00	0.30	1.00	4.00	12.00	SQM
	RCC BEAM	2.00	24.30	0.30	2.00	29.16	SQM
		2.00	9.15	0.30	2.00	10.98	SQM
	COLUMNS	10.00	0.30	1.00	4.00	12.00	SQM
	FOUNDATION	10.00	1.00	0.25	4.00	10.00	SQM
	SHORT CULUMNS	10.00	0.30	1.00	4.00	12.00	SQM
	RCC BEAM	2.00	15.25	0.30	2.00	18.30	SQM
		2.00	9.15	0.30	2.00	10.98	SQM
	COLUMNS	10.00	0.30	1.00	4.00	12.00	SQM
	FOUNDATION	8.00	1.00	0.25	4.00	8.00	SQM
	SHORT CULUMNS	8.00	0.30	1.00	4.00	9.60	SQM
	RCC BEAM	2.00	15.25	0.30	2.00	18.30	SQM
		2.00	6.10	0.30	2.00	7.32	SQM
	COLUMNS	8.00	0.30	1.00	4.00	9.60	SQM
	FOUNDATION	14.00	1.00	0.25	4.00	14.00	SQM

	SHORT CULUMNS	14.00	0.30	1.00	4.00	16.80	SQM
	RCC BEAM	2.00	30.50	0.30	2.00	36.60	SQM
		2.00	6.10	0.30	2.00	7.32	SQM
	COLUMNS	10.00	0.30	1.00	4.00	12.00	SQM
	FOUNDATION	9.00	1.00	0.25	4.00	9.00	SQM
	SHORT CULUMNS	9.00	0.30	1.00	4.00	10.80	SQM
	RCC BEAM	3.00	7.60	0.30	2.00	13.68	SQM
		3.00	6.10	0.30	2.00	10.98	SQM
	COLUMNS	9.00	0.30	1.00	4.00	10.80	SQM
	RCC BEAM	3.00	8.60	0.30	2.00	15.48	SQM
		3.00	8.10	0.30	2.00	14.58	SQM
		1.00	8.10	8.60	1.00	69.66	SQM
	FOUNDATION	6.00	1.00	0.25	4.00	6.00	SQM
	SHORT CULUMNS	6.00	0.30	1.00	4.00	7.20	SQM
	RCC BEAM	2.00	9.15	0.30	2.00	10.98	SQM
		2.00	9.15	0.30	2.00	10.98	SQM
	COLUMNS	6.00	0.30	1.00	4.00	7.20	SQM
	FOUNDATION	8.00	1.00	0.25	4.00	8.00	SQM
	SHORT CULUMNS	8.00	0.30	1.00	4.00	9.60	SQM
	RCC BEAM	2.00	9.15	0.30	2.00	10.98	SQM
		2.00	6.10	0.30	2.00	7.32	SQM
	COLUMNS	6.00	0.30	1.00	4.00	7.20	SQM
	FOUNDATION	4.00	1.00	0.25	4.00	4.00	SQM
	SHORT CULUMNS	4.00	0.30	1.00	4.00	4.80	SQM
	RCC BEAM	2.00	4.00	0.30	2.00	4.80	SQM
		2.00	3.00	0.30	2.00	3.60	SQM
	COLUMNS	4.00	0.30	1.00	4.00	4.80	SQM
	FOUNDATION	12.00	1.00	0.25	4.00	12.00	SQM
	SHORT CULUMNS	12.00	0.30	1.00	4.00	14.40	SQM
	RCC BEAM	6.00	3.00	0.30	2.00	10.80	SQM
		6.00	3.00	0.30	2.00	10.80	SQM
	COLUMNS	12.00	0.30	3.00	4.00	43.20	SQM
						711.54	SQM
6	Reinforcement for RCC work including straighten, cutting, bending, placing in position and binding all complete. A)TMT Bars. ALL 8MM & 12MM MIXED					10681.34	KG
7	Providing and Laying 12mm cement plaster of mix : a) 1: 4 (1 cement : 4 fine sand)						
	HOLLOW BLOCK	2.00	24.00	2.00	1.00	96.00	SQM
		2.00	9.15	2.00	1.00	36.60	SQM
	HOLLOW BLOCK	2.00	18.30	2.00	1.00	73.20	SQM
		2.00	9.15	2.00	1.00	36.60	SQM
	HOLLOW BLOCK	2.00	15.25	2.00	1.00	61.00	SQM
		2.00	9.15	2.00	1.00	36.60	SQM
	HOLLOW BLOCK	2.00	15.25	2.00	1.00	61.00	SQM
		2.00	6.10	2.00	1.00	24.40	SQM
	HOLLOW BLOCK	2.00	30.50	2.00	1.00	122.00	SQM
		2.00	6.10	2.00	1.00	24.40	SQM
	HOLLOW BLOCK	2.00	7.60	3.00	1.00	45.60	SQM
		2.00	6.10	3.00	1.00	36.60	SQM
		4.00	3.50	3.00	1.00	42.00	SQM
	HOLLOW BLOCK	2.00	9.15	2.00	1.00	36.60	SQM
		2.00	9.15	2.00	1.00	36.60	SQM
	HOLLOW BLOCK	2.00	6.10	2.00	1.00	24.40	SQM
		2.00	9.15	2.00	1.00	36.60	SQM
	HOLLOW BLOCK	2.00	1.00	1.00	1.00	2.00	SQM
		2.00	4.00	2.00	1.00	16.00	SQM
	HOLLOW BLOCK	6.00	3.00	3.00	1.00	54.00	SQM
		6.00	3.00	3.00	1.00	54.00	SQM
						956.20	SQM
8	Providing and laying cement concrete hallow block walling 150mm thick consisting of hollow block of size 400 x 200 x150 of mix 1:3:6 (Icement : 3 coarse sand: 6 graded stone aggregate of 10mm nominal size) laid in cement mortar 1:6 (1 cement :6 fine sand)						
		2.00	24.00	1.00	0.15	7.20	CUB
		2.00	9.15	1.00	0.15	2.75	CUB

		2.00	18.30	1.00	0.15	5.49	CUB
		2.00	9.15	1.00	0.15	2.75	CUB
		2.00	15.25	1.00	0.15	4.58	CUB
		2.00	9.15	1.00	0.15	2.75	CUB
		2.00	15.25	1.00	0.15	4.58	CUB
		2.00	6.10	1.00	0.15	1.83	CUB
		2.00	30.50	1.00	0.15	9.15	CUB
		2.00	6.10	1.00	0.15	1.83	CUB
		2.00	7.60	3.00	0.15	6.84	CUB
		2.00	6.10	3.00	0.15	5.49	CUB
		4.00	3.50	3.00	0.15	6.30	CUB
		2.00	9.15	1.00	0.15	2.75	CUB
		2.00	9.15	1.00	0.15	2.75	CUB
		2.00	9.15	1.00	0.15	2.75	CUB
		2.00	6.10	1.00	0.15	1.83	CUB
		2.00	3.00	1.00	0.15	0.90	CUB
		2.00	4.00	1.00	0.15	1.20	CUB
		6.00	3.00	3.00	0.15	8.10	CUB
		6.00	3.00	3.00	0.15	8.10	CUB
						89.88	CUB
9	Distempering with 1 st quality acrylic washable distemper (ready made) of approved manufacture and of required shade and colour complete. As manufacture's specification.						
	WALL	4.00	24.25	1.30	1.00	126.10	SQM
		4.00	9.15	1.30	1.00	47.58	SQM
	WALL	4.00	18.30	1.30	1.00	95.16	SQM
		4.00	9.15	1.30	1.00	47.58	SQM
	WALL	4.00	15.25	1.30	1.00	79.30	SQM
		4.00	9.15	1.30	1.00	47.58	SQM
	WALL	4.00	15.25	1.30	1.00	79.30	SQM
		4.00	6.10	1.30	1.00	31.72	SQM
	WALL	4.00	30.50	1.30	1.00	158.60	SQM
		4.00	6.10	1.30	1.00	31.72	SQM
	WALL	2.00	7.60	3.00	1.00	45.60	SQM
		2.00	6.10	3.00	1.00	36.60	SQM
		4.00	3.50	3.00	1.00	42.00	SQM
	WALL	4.00	9.15	1.30	1.00	47.58	SQM
		4.00	9.15	1.30	1.00	47.58	SQM
	WALL	4.00	9.15	1.30	1.00	47.58	SQM
		4.00	6.10	1.30	1.00	31.72	SQM
	WALL	4.00	3.00	1.30	1.00	15.60	SQM
		4.00	4.00	1.30	1.00	20.80	SQM
	WALL	4.00	3.00	3.00	1.00	36.00	SQM
		4.00	3.00	3.00	1.00	36.00	SQM
						1151.70	SQM
10	Add Internal Electrification and Sanitary Installation on 9%					#REF!	
						#REF!	
11	Fixing of Door and Window					1.00	l/s
12	Fabrication of steel Structure Bulilding	24.25	9.15	25.00		5547.19	KG
		15.25	9.15	25.00		3488.44	KG
		15.25	6.10	25.00		2325.63	KG
		30.50	6.10	25.00		4651.25	KG
		9.15	9.15	25.00		2093.06	KG
		9.15	6.10	25.00		1395.38	KG
		3.00	4.00	25.00		300.00	KG
		3.00	3.00	25.00	3.00	675.00	KG
						20475.94	KG
13	Fixing of Corragate Roofing Sheet	24.25	2.00	4.00		194.00	SQM
		9.15	2.00	4.00		73.20	SQM
		10.35	25.70			266.00	SQM
		18.30	2.00	4.00		146.40	SQM
		9.15	2.00	4.00		73.20	SQM
		10.35	19.50			201.83	SQM
		15.25	2.00	4.00		122.00	SQM

		9.15	2.00	4.00		73.20	SQM
		10.35	16.50			170.78	SQM
		15.25	2.00	3.00		91.50	SQM
		6.10	2.00	3.00		36.60	SQM
		7.30	16.50			120.45	SQM
		6.10	2.00	3.00		36.60	SQM
		9.15	2.00	4.00		73.20	SQM
		9.15	2.00	4.00		73.20	SQM
		10.45	10.50			109.73	SQM
		9.15	2.00	3.00		54.90	SQM
		6.10	2.00	3.00		36.60	SQM
		7.20	10.45			75.24	SQM
		4.00	2.00	1.00		8.00	SQM
		3.00	2.00	1.00		6.00	SQM
		4.00	2.90			11.60	SQM
						2054.21	SQM

PART-I

Date: _____

From,

Name:
Address:
Ph:
Fax:
E-mail:

To,

The Secretary,
M/s.Yuvasakthi,
Near IACT Computer Education, MG Road, Junglighat (Post),
Port Blair, South Andaman – 744 103

Sir,

Sub: Tender for the construction of Industrial Work shed buildings and amenities
for Andaman Coir Cluster - Submission of Part I - Reg
Ref: Your Tender Notice Dt.

With reference to your tender notice, we submit herewith our sealed Tender for
the construction of Industrial Work shed buildings and amenities for Andaman Coir Cluster,
as specified by IA in this tender document.

We enclose the following documents:

- 1) Tender conditions duly signed in each page and enclosed in token of accepting
the Tender conditions
- 2) Demand Draft no. _____ for Rs.1,50,000 /- (Rupees One lakh Fifty thousand
only), in favour of “HI Account Andaman Coir Cluster”, Drawn on
_____ Bank payable at Port Blair, towards Earnest Money Deposit.
- 3) Authorization letter from the Company for the person to sign the tender.
- 4) Details of the Tenderer (as per Annexure-III)
- 5) Average annual turnover statement duly certified by a Chartered Accountant (as
per Annexure-IV).
- 6) List of Building construction works executed in last 3 years as per Annexure-V
- 7) Declaration for not having black listed by any other Govt. agencies (as per
Annexure-VI).
- 8) Declaration for not having tampered the Tender documents downloaded from the
websites **www.coirboard.gov.in** or **www.itcot.com** (Annexure-VII).
- 9) The copy of certificate of incorporation/registration (If applicable)
- 10) Copy of Memorandum and Articles of Association (If applicable)

- 11) Copy of Registered Partnership deed, in case of Partnership Firm (If applicable)
- 12) Copy of Udyog Aadhaar, GST Registration Certificate & PAN Card
- 13) Valid Registration Certificate from Valid Registration Certificate from PWD / CPWD / Highways department
- 14) Work Orders issued by the clients.
- 15) Performance certificate issued by the clients.
- 16) The Annual Report / certified copies of Balance Sheet, Profit & Loss statement along with schedules for the last 3 consecutive financial years FY 2016-17, 2017-18 and 2018-19.
- 17) Latest I.T return.
- 18) Notarized translated English version of the documents in a language other than English/Tamil, if any.

Yours faithfully,

SIGNATURE OF THE TENDERER

Encl: As stated above

ANNEXURE - III**DETAILS OF THE TENDERER**

1. Name of the Tenderer	
2. Registered Office Address	Telephone Number: Fax : Email : Website, if any
3. Contact Person	Name: Designation: Phone: Mobile: Email:
4. Date of Incorporation	
5. Legal Status	Proprietorship/partnership/Pvt. Limited/Public Limited/ others(Pl. mention)
6. Eligible license holder of	
7. Brief profile of the tenderer	
8. Number of staffs on regular payroll	Technical: Administration:
9. PAN Number	
10. GST Registration Number	

SIGNATURE OF THE TENDERER
(with seal and address)

ANNUAL TURN OVER STATEMENT

The Annual turnover of M/s for the past three years are given below and certified that the statement is true and correct.

S.no	Year	Turnover (Rs. in lakh)
1	2016-2017	
2	2017-2018	
3	2018-2019	
	Total	
Average annual turnover		

DATE :

SIGNATURE OF THE TENDERER

**SIGNATURE OF CHARTERED ACCOUNTANT
(with seal and Address)**

ANNEXURE - V

List of clients for whom Civil construction works undertaken in the past 3 years

(Please provide the details for each project in separate sheet along with work Order/completion certificate from client)

S.No	Name & Address of the Client	Details of Work	Extent/Area covered in Sq.ft	Year of Completion	Cost (Rs.in Lakhs)	Work Order & Completion certificate enclosed (Yes/No)
1.						
2.						
3.						
4.						
5.						
6.						
7.						
8.						
9.						
10.						

SIGNATURE OF THE TENDERER
(with seal and address)

CERTIFICATE

Date: _____

Certified that M/s...../ the firm /company or its partners / share holders had not been blacklisted by any Government Agencies.

SIGNATURE OF THE TENDERER
(with seal and address)

DECLARATION FORM

Date: _____

a) I/We having our office at do declare that I/We have carefully read all the conditions of tender sent to me/us by the M/s.Yuvasakthi, for the tenders floated vide tender ref.no._____ for the construction of Industrial Work shed buildings and amenities for Andaman Coir Cluster and will complete the contract as per the tender conditions.

b) I/We have downloaded the tender document from the internet site **www.coirboard.gov.in** or **www.itcot.com** and I/We have not tampered / modified the tender document in any manner. In case, if the same is found to be tampered / modified, I/ We understand that my/our tender will be summarily rejected and full Earnest Money Deposit will be forfeited and I /We am/are liable to be banned from doing business with M/s.Yuvasakthi or prosecuted.

SIGNATURE OF THE TENDERER
(with seal and address)

PART-II

From,

Name:
Address:
Ph:
Fax:
E-mail:

To,

The Secretary,
M/s. Yuvasakthi,
Near IACT Computer Education, MG Road, Junglighat (Post),
Port Blair, South Andaman – 744 103

Sir,

Sub: Tender for the construction of Industrial Work shed buildings and amenities for Andaman Coir Cluster - Submission of Part II - Price Offer-Reg.

Ref:- Our tender (Technical Bid) submitted for the “Construction of Industrial Work shed buildings and amenities for Andaman Coir Cluster”

In continuation of our above tender, we submit herewith the price offer for the “Industrial Work shed buildings and amenities for Andaman Coir Cluster” as specified by IA in this tender document.

We agree to abide by the terms and conditions stipulated by the IA and also agree to complete the entire contract, at the rates quoted by us. The rate quoted and approved by the IA in this tender will hold good as per IA tender conditions.

Yours faithfully,

SIGNATURE OF THE TENDERER

PRICE BID

(Amount in Rs.)

Description	Basic Amount	SGST	CGST	IGST	Total Price including taxes
Construction of work shed building and amenities for the common facility centre of Andaman Coir Cluster as per drawing and BoQ given in Annexure I					
Grand Total					

Amount in Words: Rupees _____ only

Note:

- a) The Bidder shall quote the Lump sum costs in the above given format.
- b) The lump sum offer shall provide for all superintendence, labour, technical assistance, material, plant, equipment and all other things required for executing and completing all the works as per defined Scope of Work.

SIGNATURE OF THE TENDERER
(with seal and address)

CHECKLIST OF DOCUMENTS**Documents to be enclosed in Part-I:**

S.No	Checklist	Enclosed (Yes/No)	Reference in the Bid (Page No.)
1.	A covering letter on your letter head addressed to the Secretary, M/s. Yuvasakthi, Near IACT Computer Education, MG Road, Junglighat (Post), Port Blair, South Andaman – 744 103 (as per Annexure-II)		
2.	Tender conditions duly signed in each page and enclosed in token of accepting the Tender conditions		
3.	Demand Draft for Rs.1,50,000/- (Rupees One lakh Fifty thousand only), in favour of “HI Account Andaman Coir Cluster”, payable at Port Blair, towards Earnest Money Deposit.		
4.	Authorization letter from the Company for the person to sign the tender		
5.	Details of the Tenderer (as per Annexure-III)		
6.	Average annual turnover statement duly certified by a Chartered Accountant (as per Annexure-IV)		
7.	List of Building construction works executed in last 3 years as per (Annexure-V)		
8.	Declaration for not having black listed by any other Govt. agencies (as per Annexure-VI)		
9.	Declaration for not having tampered the Tender documents downloaded from the websites www.coirboard.nic.in or www.itcot.com (Annexure-VII).		
10.	The copy of certificate of incorporation/registration.		
11.	Copy of Memorandum and Articles of Association		
12.	Copy of Registered Partnership deed, in case of Partnership Firm		
13.	Copy of Udyog Aadhaar, GST Registration Certificate & PAN Card		

S.No	Checklist	Enclosed (Yes/No)	Reference in the Bid (Page No.)
14.	Valid Registration Certificate from PWD / CPWD / Highways department		
15.	Work Orders issued by the clients		
16.	Performance certificate issued by the clients		
17.	The Annual Report / certified copies of Balance Sheet, Profit & Loss statement along with schedules for the last 3 consecutive financial years FY 2016-17, 2017-18 and 2018-19.		
18.	Latest I.T return		
19.	Notarized translated English version of the documents in a language other than English/Tamil, if any		

Documents to be enclosed in Part-II

S.No	Checklist	Enclosed (Yes/No)
1.	A covering letter on your letter head addressed to the Secretary, M/s. Yuvasakthi, Near IACT Computer Education, MG Road, Junglighat (Post), Port Blair, South Andaman – 744 103 (as per Annexure-VIII)	
2.	Price Bid as per Annexure- IX of the Tender document.	

Both ‘Part I – Technical bid’ cover and ‘Part II – Price bid’ cover must be placed in a separate sealed cover superscripted as “Tender for the construction of Work shed buildings and amenities for Andaman Coir Cluster” and addressed to “M/s.Yuvasakthi, Near IACT Computer Education, MG Road, Junglighat (Post), Port Blair, South Andaman – 744 103”, containing the name and address of the Tenderer.

Note: Tenders submitted in unsealed cover would summarily be rejected.