



# कयर बोर्ड Coir Board

(सूक्ष्म, लघु और मध्यम उद्यम मंत्रालय, भारत सरकार  
Ministry of MS&ME, Govt. of India)

कयर हाउस, एम.जी.रोड., कोच्ची - 682016  
Coir House, M.G. Road, Kochi - 682016  
तार/ Gram : COIR BOARD  
दूरभाष/ Ph : 0484-2351954, 2351807, 2351788  
फैक्स / Fax : 0484-2370034, 2354397  
ई-मेल/ E-mail : coir@md2.vsnl.net.in  
वेब/ Web : www.coirboard.nic.in, www.coirboard.gov.in

## **TENDER NO. I-12019/19/2016-EXPORT MARKETING-I, Dated: 21 November, 2017**

### **Construction and Maintenance of Coir Board Pavilion at Domotex Hannover, 2018**

Coir Board regularly participates in the Domotex International Trade Fair, Hannover, Germany. The primary objective of participation is to depict the capabilities of Indian coir sector before the global trading community on floor covering products.

Coir Board requires the services of a professional agency with proven track record in the respective fields at international levels for designing, fabrication, construction and maintenance of the Coir Board Pavilion and other related ancillary activities in Domotex Hannover 2018, as per the scope of work given below.

#### **A. SCOPE OF WORK**

Coir Board Pavilion has to be constructed in 294 Sq.mtr. area, in three locations in Hall 4 of Domotex International Trade Fair, Hannover, Germany scheduled to be held during 12-15 January, 2018. The Coir Board Pavilion would comprise of three independent pavilions as detailed below:

Stand No. B 90 –I Pavilion of 150 Sq.mtr.  
Stand No. F 79 – II pavilion of 72 Sq.mtr.  
Stand No. F 80 - III Pavilion of 72 Sq.mtr.

COIR BOARD PAVILION SHALL BE CONSTRUCTED IN WOOD WITH LOW COST MATERIAL LIKE PARTICLE BOARD GIVING REQUIRED ELEVATION TO ENSURE VISIBILITY FROM ALL SIDES AND DISTANT LOCATIONS WITH A UNIQUE DESIGN SUITING TO THE INTERNATIONAL STANDARDS AND CREATING A GOOD APPEAL. ALL THE THREE PAVILIONS SHALL BE CONSTRUCTED ON AN ELEVATED PLATFORM OF 15 CM HEIGHT. PAVILIONS SHOULD ALSO BE RECOGNIZABLE AS INDIAN COIR PAVILION.

#### **A.1. SPECIFICATIONS AND ANCILLARY REQUIREMENTS**

A.1.1 The Concept/Design and other specifications relating to design/ decoration / display, for the Coir Board Pavilion at Domotex should be suiting to the **international standards.**

A.1.2 The total area of the Coir Board Pavilion at the Domotex, 2018 is 294 sq. mtrs. in three locations in Hall No. 4. The layout of Hall No. 4 and Coir Board pavilions are attached.

A.1.3 The booths in the Coir Board pavilions would be as below:

(a)	12 Sq.mtr. booths	-	8 Nos.
(b)	18 Sq.mtr. booths	-	2 Nos.
(c)	20 Sq.mtr. booth	-	1 No.
(d)	24 Sq.mtr. booths	-	2 Nos.
(e)	28 Sq.mtr. booth	-	1 No.
(f)	30 Sq.mtr. booth	-	1 No.
(f)	36 Sq.mtr. booth	-	1 No.

The 36 Sq.mtr. Booth would be Board's own stand which shall be designed as a facilitating office-cum-theme pavilion with reception area, VIP Lounge, Discussion Room and a small cafeteria with storage space. There should be visible signages /fascia for the pavilions as well as all participants/co-exhibitors in the Pavilion with logo, if any. A common branding named as **Indian Coir** with visuals of Logos of Ministry of MSME, Coir Board, Make in India and Flying National Flag shall be provided with branding on both sides on the top of the inner partition wall across the length of the pavilion with a height of 1.5 meters (as shown in the 3D view which should be taken as an informative sample).

A.1.4 Arrangements shall be made for covering the entire pavilions for the sake of security during the eve of the fair opening and also on 12, 13 & 14 January, 2018.

A.1.5 The interior decoration and display requirements of individual booths shall be as shown below:

**(a) 12 Sq.mtr. booth**

- i. Fascia with company name & Logo, if any (booth wise as per the list provided by Coir Board).
- ii. Eye Catching Sign Board on the back wall of the booth
- iii. Wall panel
- iv. Carpeting the entire area.
- v. Proper light and electrical arrangements with spot lights as prescribed in para A.1.7.
- vi. Particle Board/perforated panel in front of the system wall (entire area) with screwing facility to fix mats measuring 45 x 75 cm.
- vii. One Catalogue stand.
- viii. One round table + four chairs
- ix. Wi-Fi Facility
- x. One Rubbish bin

**(b) 18, 20, 24 Sq.mtr. booths**

- i. Fascia with company name & Logo, if any (booth wise as per the list provided by Coir Board).
- ii. Eye Catching Sign Board on the back wall of the booth
- iii. Wall panel
- iv. Carpeting the entire area.
- v. Proper light and electrical arrangements with spot lights as prescribed in para A.1.7.
- vi. Particle Board/perforated panel in front of the system wall (entire area) with screwing facility to fix mats measuring 45 x 75 cm.
- vii. One lockable cupboard on the wall with 1 mtr. Width for storing valuables and also with facility for display on the doors of the cupboard.
- viii. Two Catalogue stands.
- ix. Two round tables + Eight chairs
- x. Wi-Fi Facility
- xi. Two Rubbish bins

**(c) 28 & 30 Sq.mtr. booth**

- i. Fascia with company name & Logo, if any (booth wise as per the list provided by Coir Board).
- ii. Eye Catching Sign Board on the back wall of the booth
- iii. Wall panel
- iv. Carpeting the entire area.
- v. Proper light and electrical arrangements with spot lights as prescribed in para A.1.7.
- vi. Particle Board/perforated panel in front of the system wall (entire area) with screwing facility to fix mats measuring 45 x 75 cm.
- vii. A locking cupboard on the wall with 1 mtr. Width for storing valuables and also with facility for display on the doors of the cupboard.
- viii. Three Catalogue stands.
- ix. One lockable cupboard on the wall with 1 mtr. Width for storing valuables and also with facility for display on the doors of the cupboard.
- x. Three round tables + Twelve chairs
- xi. Wi-Fi Facility
- xii. Three Rubbish bins

**(d) 36 Sq.mtr. booth (Coir Board)**

- i. Fascia with company name & logo
- ii. Eye Catching Sign Board on the back wall of the booth
- iii. Wall panel
- iv. Carpeting the entire area
- v. Theme pavilion-cum-Reception area

- vi. Discussion Room to accommodate 6 persons with required quality seating arrangements and sufficient moving space.
- vii. One 60 inch Plasma TV + DVD player for continuous display of ad films
- viii. Graphics in the theme pavilion of Coir Board.
- ix. One Tea/Coffee maker with all related ingredients for supply of Tea/Coffee & Snacks to the guests for the entire pavilion as per requirement during the fair timings.
- x. Proper light and electrical arrangements with spot lights as prescribed in para A.1.7.
- xi. Particle Board/Perforated panel in front of the system wall (entire area) with screwing facility to fix mats measuring 45 x 75 cm.
- xii. One lockable cupboard on the wall with 1 mtr. Width for storing valuables and also with facility for display on the doors of the cupboard.
- xiii. Two Catalogue stands.
- xiv. Two Round tables + Eight chairs
- xv. Wi-Fi Facility
- xvi. Two Rubbish bins

A.1.6 Tea/Coffee Maker and one Receptionist-cum-Interpreter-cum-Attendant shall be provided to the pavilion through Board's booth. The entire area of the Board's pavilion shall be furnished by the agency.

A.1.7. The scope of work will also include provision for electrical fittings in the pavilion as per requirements, as well as daily cleaning, maintenance and upkeep of the pavilion during the course of the exhibition. The spot light shall be arranged in such a way so as to ensure illumination of products on display on the particle board on all the walls from top to bottom and one side to the other side. In addition to the spot light focusing products on display, adequate light arrangements should be ensured for every booth. The minimum spot light requirements of different booths and other electrical requirements are as below:

(a)	12 Sq.mtr. one side open booths	-	10 spot lights
(b)	12 Sq.mtr. two side open booths	-	7 spot lights
(c)	18 Sq.mtr. booths	-	9 spot lights
(d)	20 Sq.mtr. booth	-	9 spot lights
(e)	24 Sq.mtr. booths in Stand No.B 90	-	10 Spot lights
(f)	24 Sq.mtr. booths in Stand No.F 80	-	11 Spot lights
(g)	28 Sq.mtr. booth	-	15 Spot lights
(h)	30 Sq.mtr. booth	-	12 Spot lights

- a. As required for illumination of products on display and all other area in Coir Board Booth as per the design of the theme pavilion.
- b. Two power point plugs each for all the booths except 28 Sq.mtr. and 36 Sq.mtr. booths, one for working laptop and the other for purposes like charging hand-phones.

- c. Six power point plugs in Board's booth - One each for laptop, TV, DVD, Tea maker and for other purposes and five power point plugs for 28 Sq.mtr. booth.
- d. Proper lighting should be provided especially for the elevated portion of the pavilion and generally for the entire pavilion structure.

A.1.8 The work will include construction of the pavilion at site well in time, maintenance activities during the period of the Fair and dismantling of the pavilion after the event including procurement and transportation of materials.

A.1.9 All the other ancillary works related to Coir Board Pavilion like preparation of wall graphics, positioning of logos, and visual of flying National Flag and writing as 'Indian Coir' and creating branding for Indian Coir with visibility from distance are within the scope of work of the agency.

## **B. GUIDELINES FOR SUBMISSION OF TENDERS**

The technical and financial bids for construction of Coir Board Pavilion at Domotex, 2018 should be **submitted separately** and should include the following:

**Cover – 1 :** Superscribed with "**Technical bid for construction of Coir Board Pavilion at Domotex, 2018**" and should accompany the following documents:

- i. Profile of the Agency / Company.
- ii. Details of Technical Manpower and Staff available in-house.
- iii. Track record - details of involvement in similar events.
- iv. Specific experience relating to Domotex or any other international floor covering fair.
- v. Financial Statements signed by a statutory auditor, indicating turnover of the company, balance sheet and Profit & Loss Account for last three years.
- vi. **Proposed design of Coir Board pavilion with interior layout and facilities provided to different types of booths, with 3D drawings in colour, showing all over view, single booth view, bird's eye view and all sides' elevations.**
- vii. Copies of Income Tax Returns submitted for last three years with PAN.
- viii. **EMD of Rs.65,000/- or USD 1000/- shall be remitted along with the technical bid**, in the form of Demand Draft, Bankers' Cheque or Pay Order drawn in favour of the Secretary, Coir Board payable at Ernakulam, Kerala, India. EMD will be returned to the unsuccessful Tenderers at the earliest and latest within 30 days after the award of the work contract.

Note: **Clauses (i), (ii), (iii), (iv), (v), (vii) and (viii) shall not be applicable to the agencies already empanelled with Coir Board for similar work subsequent to the Expression of Interest called for vide notification issued on 13.10.2016.**

**Cover – 2 :** Superscribed with "**Financial bid for construction of Coir Board pavilion at Domotex, 2018**" and should accompany the following documents.

1. A Financial Bid, clearly indicating the cost against the following heads
  - a. Designing, construction, maintenance & dismantling of the pavilion.
  - b. Decoration and Display within the pavilion.
  - c. Transportation of material, if any, to the site and back.
  - d. Expenditure on other activities as listed in the scope of work above.  
**(Head wise indication of cost is essential)**
  
2. (i) The financial bid (all inclusive) should be specified preferably in Indian Rupees. Payment in foreign currency shall be considered only against requests. In case payment is desired in foreign currency, the same should be clearly indicated in the bid'.  
  
(ii)**Terms of Payment:** Payment will be made to the bidder as per following schedule:
  - a. Advance shall be paid, on mutually agreed percentage of the value of the contract, in Indian Rupees / foreign currency on award of the work order and on furnishing of Bank guarantee for the amount.
  - b. Balance after completion of the event and dismantling of the pavilion, i.e. within 15 days of the reporting of completion of the dismantling of the pavilion.
  - c. Taxes as applicable will be deducted at source while making payment by Coir Board.

The outer sealed cover containing the above 2 sealed Covers to be superscribed with "**Bids for construction of Coir Board pavilion at Domotex, 2018**" and should have the Full Name, Postal Address, Fax, E-mail, Telephone number of the Bidder on the bottom left corner.

**The Bids as per details given above should be submitted to the Secretary, Coir Board, Coir House, Kochi - 682 016, Kerala, India on or before 1500 hrs. on 8 December, 2017. Technical and Financial bids received by Email/Fax and bids received beyond the appointed time will not be accepted. A pre-bid meeting shall be organized at the Office of Coir Board at Kochi at 14.00 Hrs. on 5 December, 2017 for clarifying issues and clearing doubts, if any. Interested bidders may take part in the meeting either directly or through authorized representatives, if found necessary.**

### **C. ADDITIONAL INFORMATION**

- (i) The pavilion in the full-fledged form shall be handed over to the Officer-in-Charge of the Coir Board Pavilion by **15.00 Hours local time on 10 January, 2018**.
- (ii) Adequate and sufficient manpower shall be deployed for fixing exhibits on the walls in 2 or more groups and exhibits fixing shall be done on first-cum-first served basis and no additional changes shall be levied from the co-exhibitors.

- (ii) Coir Board reserves the right to reject or accept any offer without assigning any reasons whatsoever. The successful bidder will have to enter into an Agreement and an Integrity Pact with Coir Board.
- (iii) Selection of Agency(ies) will be based on the technically acceptable design and pattern of the pavilion suggested and lowest quote received for the work.
- (iv) Conditional bids will be rejected outright. The quoted price should be all inclusive (including taxes, levies etc.). The expenditure should be indicated both in words and figures. Corrections/overwriting have to be avoided. All pages should be signed by the authorized signatory.
- (v) **Security Deposit/ Performance Guarantee:** Before awarding the contract the Agency(ies) will be asked to deposit 5% of the tendered amount as **Security Deposit/Performance Guarantee**, in case Coir Board deems it necessary, in the form of Account Payee Demand Draft / Pay order from a nationalized/scheduled/commercial bank or Bank Guarantee, which should remain valid for a period of sixty days beyond the date of completion of all contractual obligations of the bidder. The Security Deposit/Bank Guarantee will be released after satisfactory completion of the contractual period.
- (vi) **Validity of Bid:** Bid shall remain valid for acceptance for the contractual period from the date of opening of Bid.
- (vii) **Opening of the Bids:** The Tenders will be opened at **15.30 hrs. on 8 December, 2017**, in Coir House, M. G. Road, Kochi, India in the presence of bidders or duly authorized representatives of the bidders, if any.
- (viii) **Insurance:** Insurance, including transit insurance will be arranged by the bidder.
- (ix) **Liquidated Damages:** In the event of bidder's failure to complete the work within the specified time, Coir Board may, without prejudice to its any other rights hereunder, recover from the bidder, as Liquidated Damages, the sum of 5 % of the contract price.
- (x) **Termination by default:** Coir Board reserves the right to terminate the contract of any agency in case of change in the Government procedures or unsatisfactory services.
- (xi) **Risk and cost Clause:** If the contractor, after submission of tender and the acceptance of the same, fails to abide by the Terms and Conditions of the tender document or fails to complete the work within the specified time or at any time repudiates the contract, the Board will have the right to:
  - a. Forfeit the EMD
  - b. Invoke Security Deposit / Performance Bank Guarantee

- c. In case of completion through alternative sources and if price is higher, the contractor will pay the balance amount to the Board.
  - d. For all purposes, the work order issued by the Board will be considered as the formal contract.
- (xii) **Arbitration**: Provisions of India Arbitration Act 1996 & 2002 will be applicable and venue of arbitration will be Ernakulam.
- (xiv) **Jurisdiction**: The contract shall be interpreted and governed by the Laws of India. In the event of any dispute/ litigation between the agency with whom the work is entrusted and the Board in respect of any of the conditions/provisions of this document or the agreement to be executed while awarding the work, the decision of Chairman, Coir Board shall be final and binding on both the parties and any litigation arising out of this document/agreement shall be subject to the jurisdiction of Courts at Kochi, Kerala, India only.

(Signed)  
**Secretary**  
**Coir Board**



Stand No. F 79 & 80

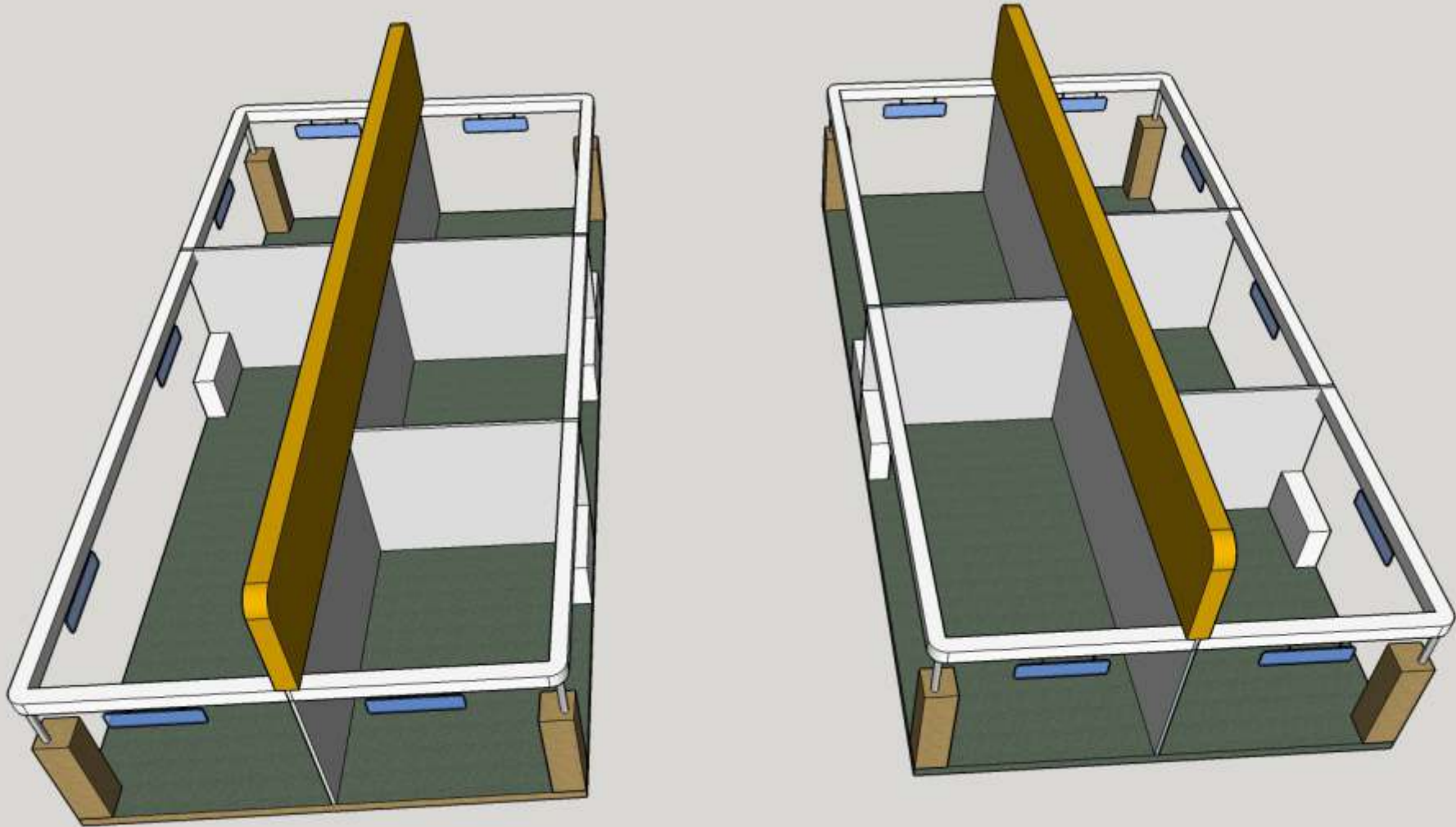

## Stand No. F 79 & 80

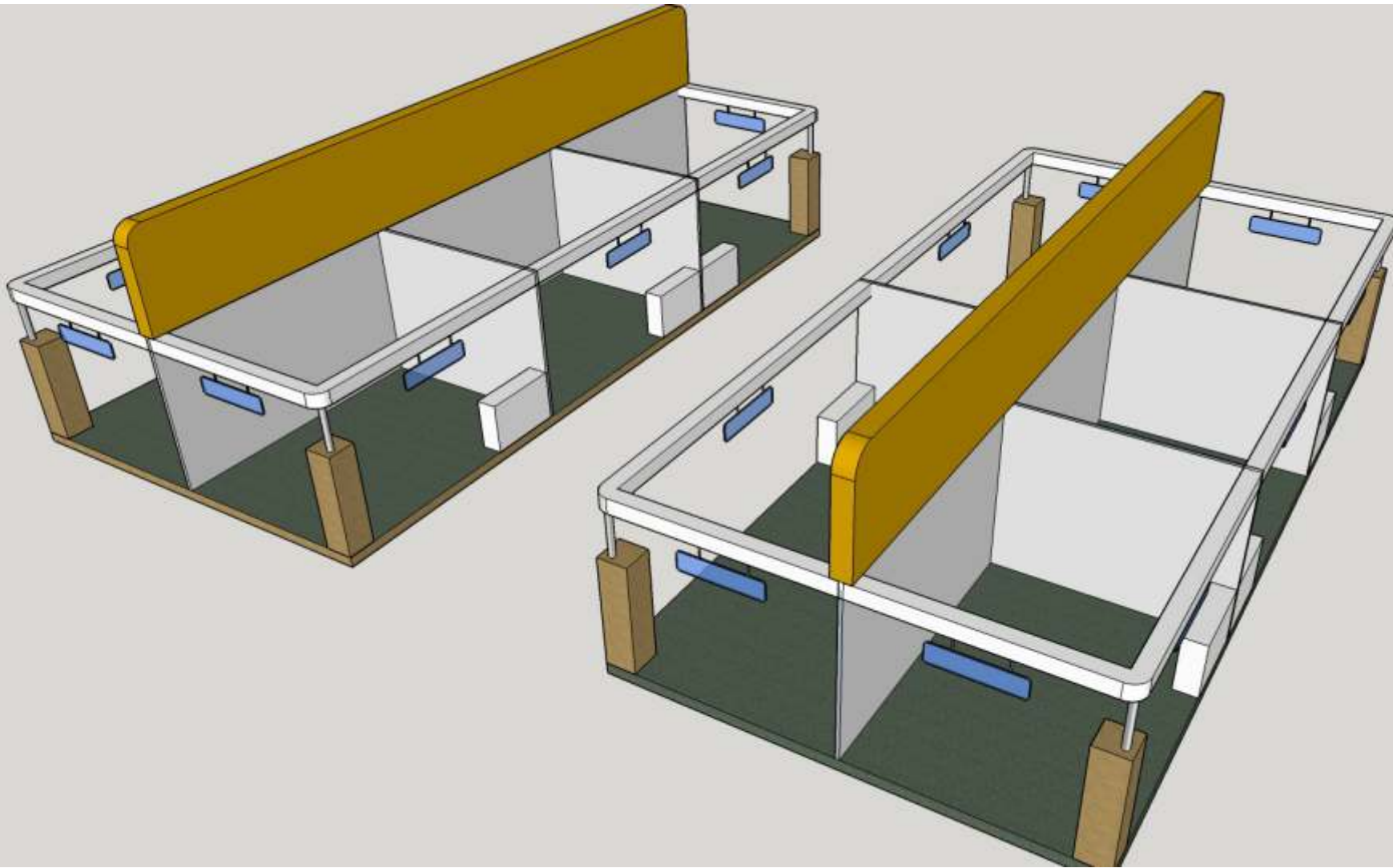

**Stand No. F 79 & 80**



**Stand No. F 79 & 80**



**Stand No. F 79 & 80**



## Stand No. F 79 & 80

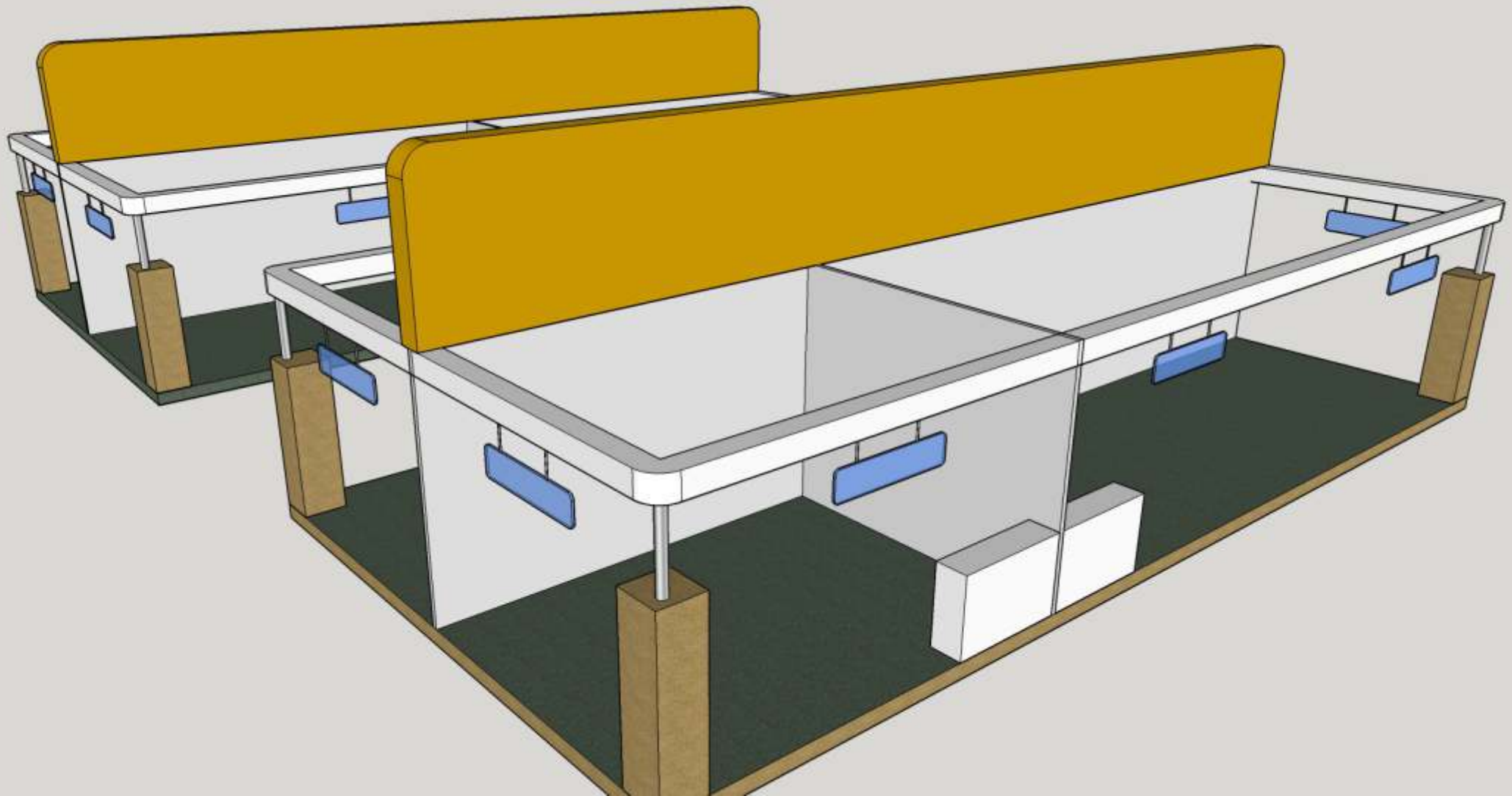

**Stand No. F 79 & 80**

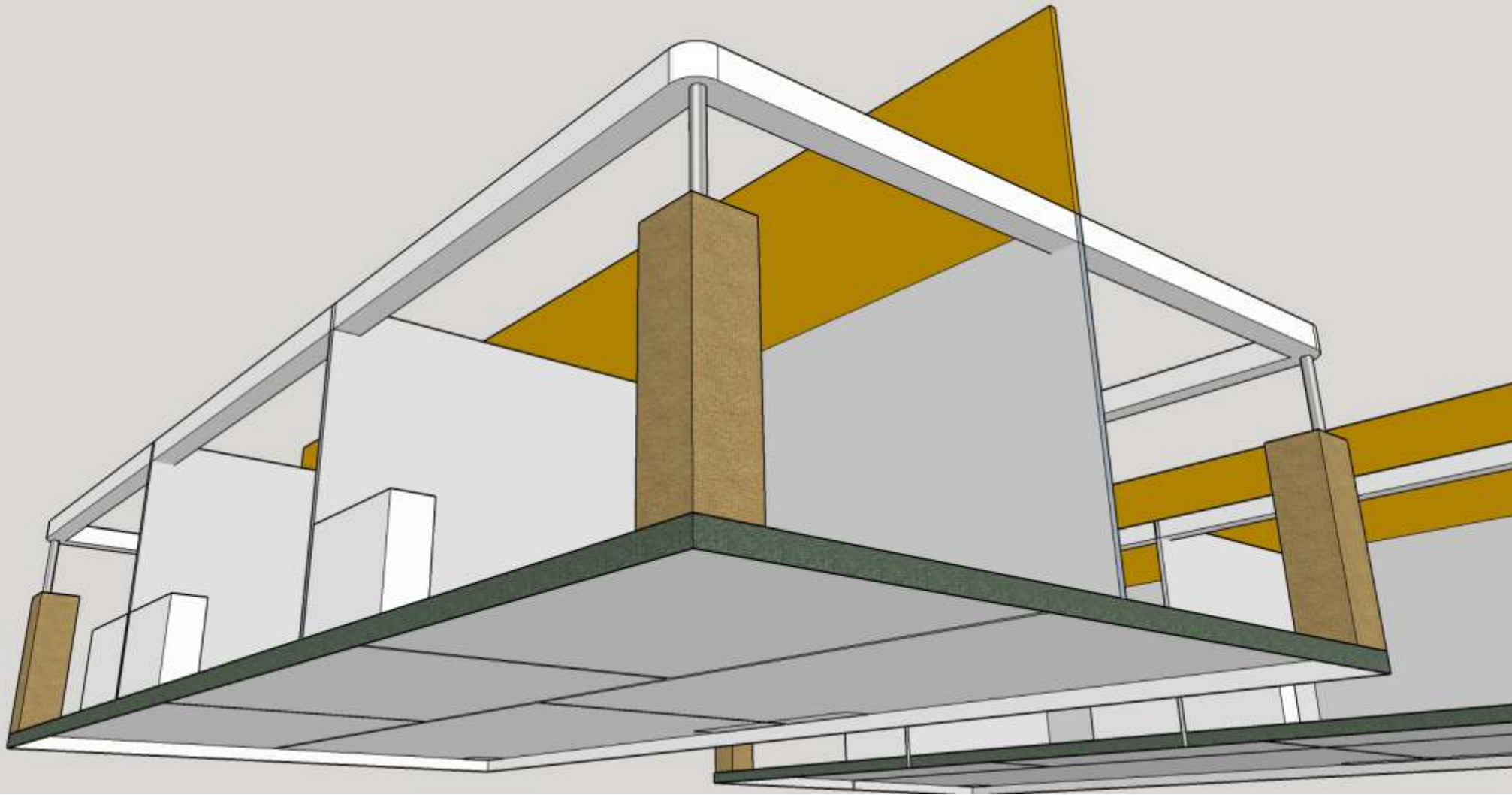

**Stand No. F 79 & 80**

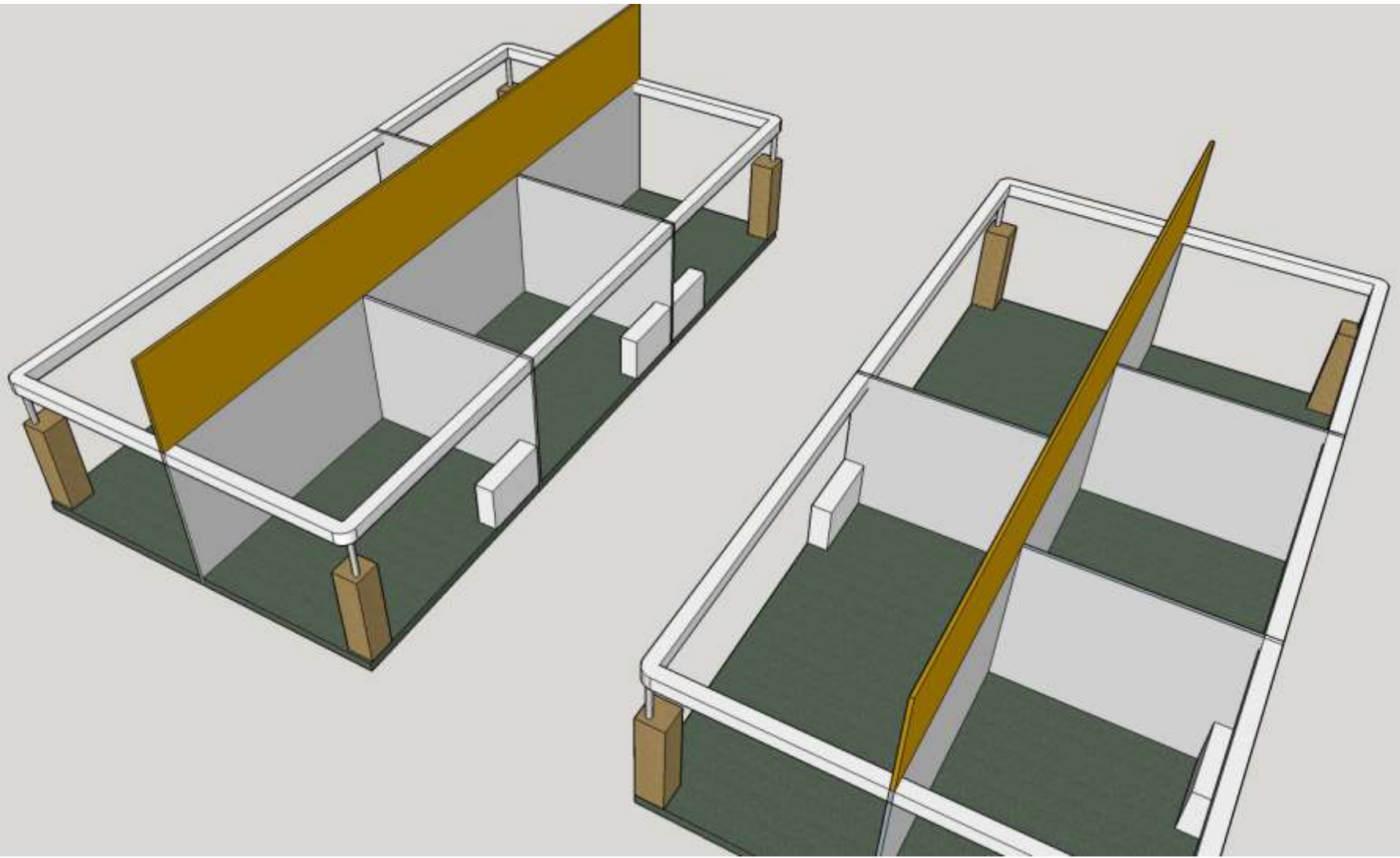



**Stand No. F 79 & 80**

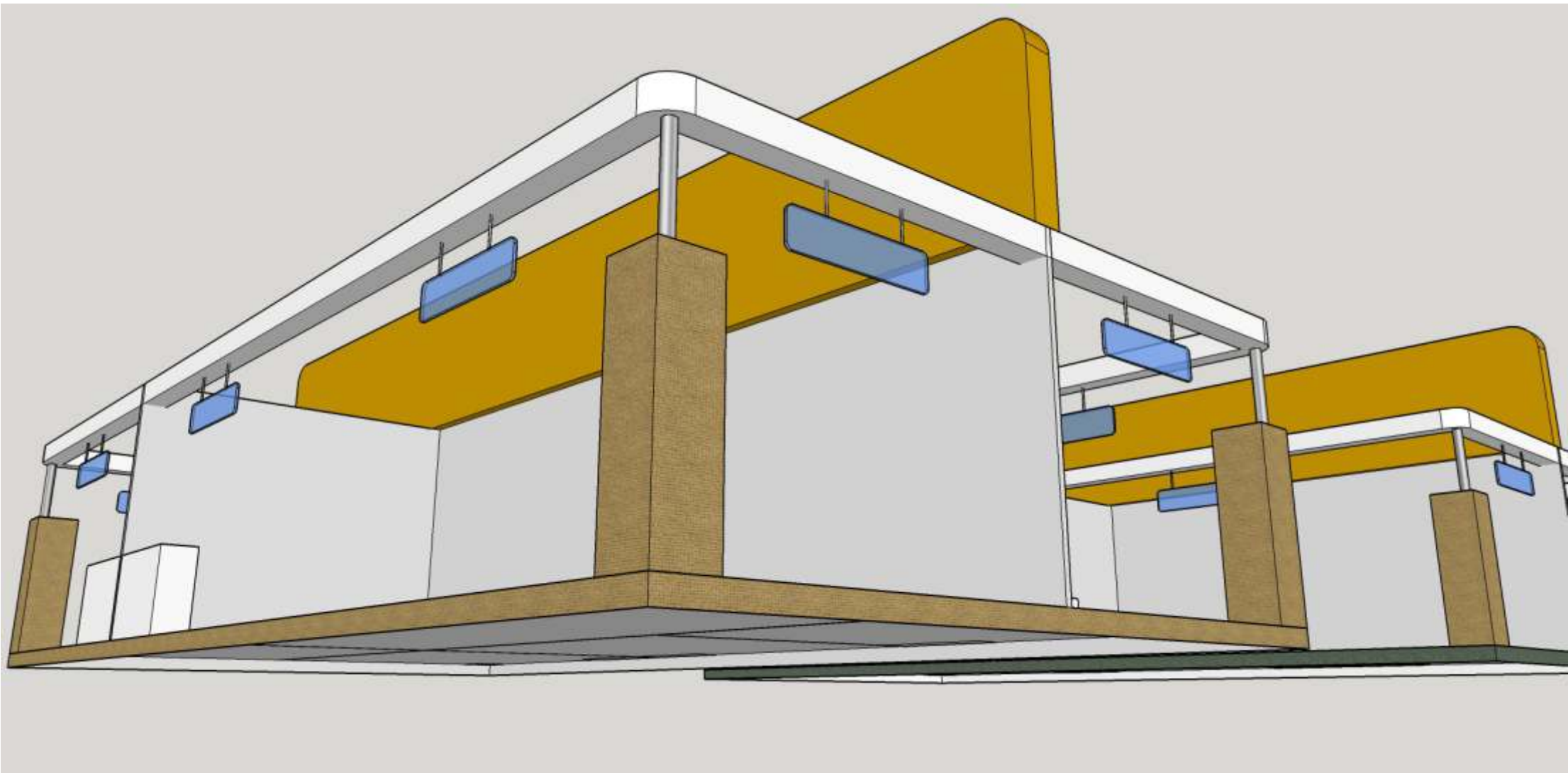

**Stand No. F 79**

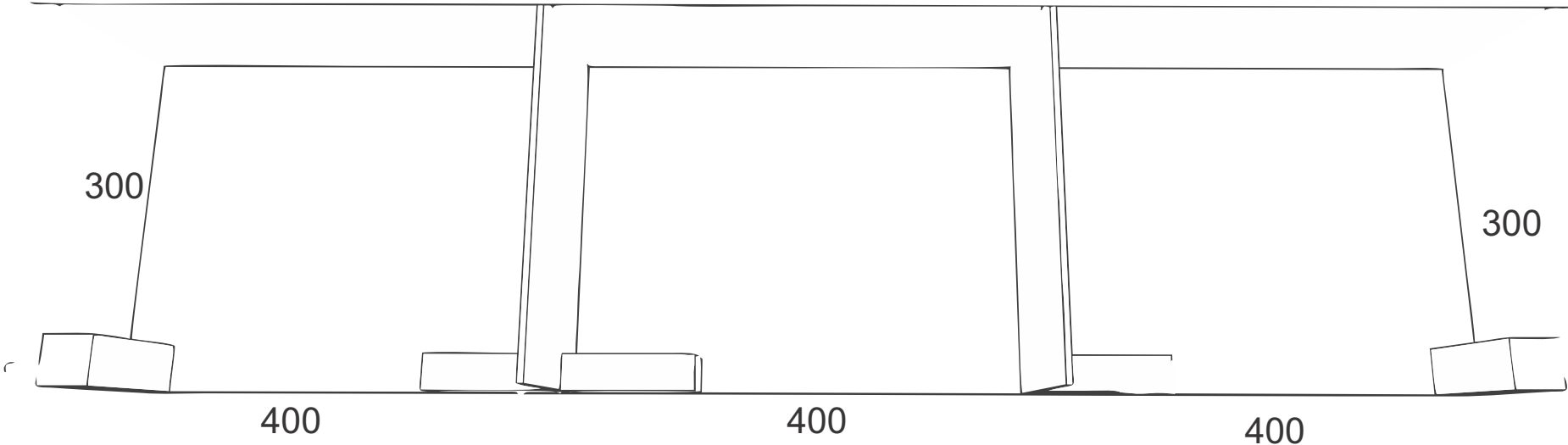
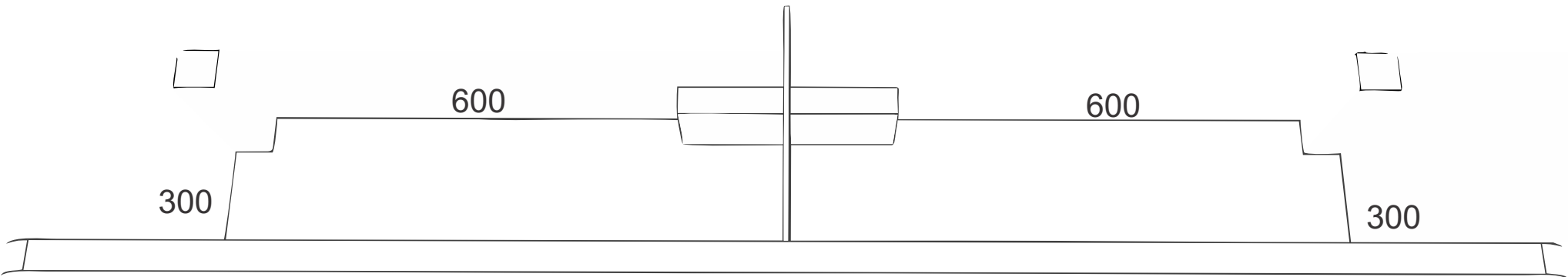

# Stand No. F 80

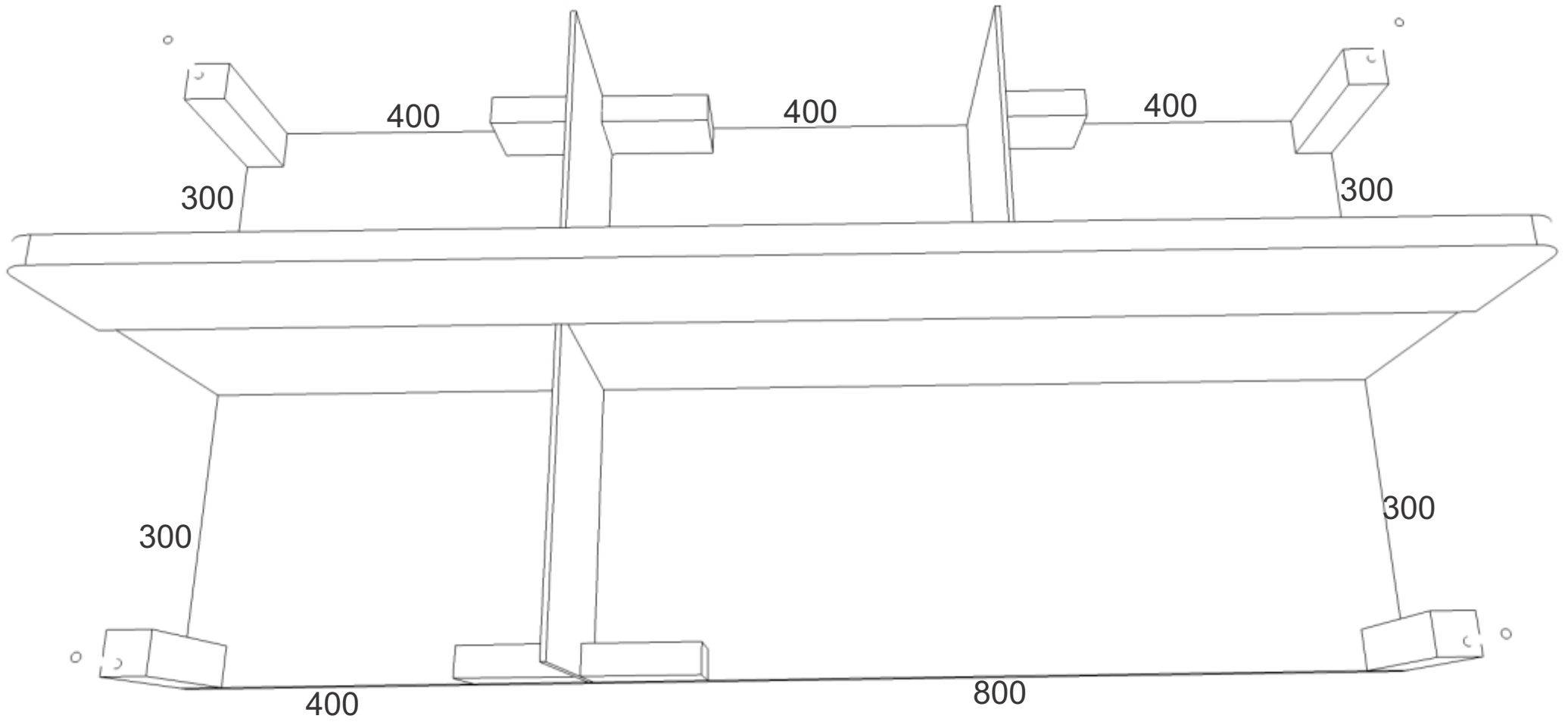

# Stand No. B 90

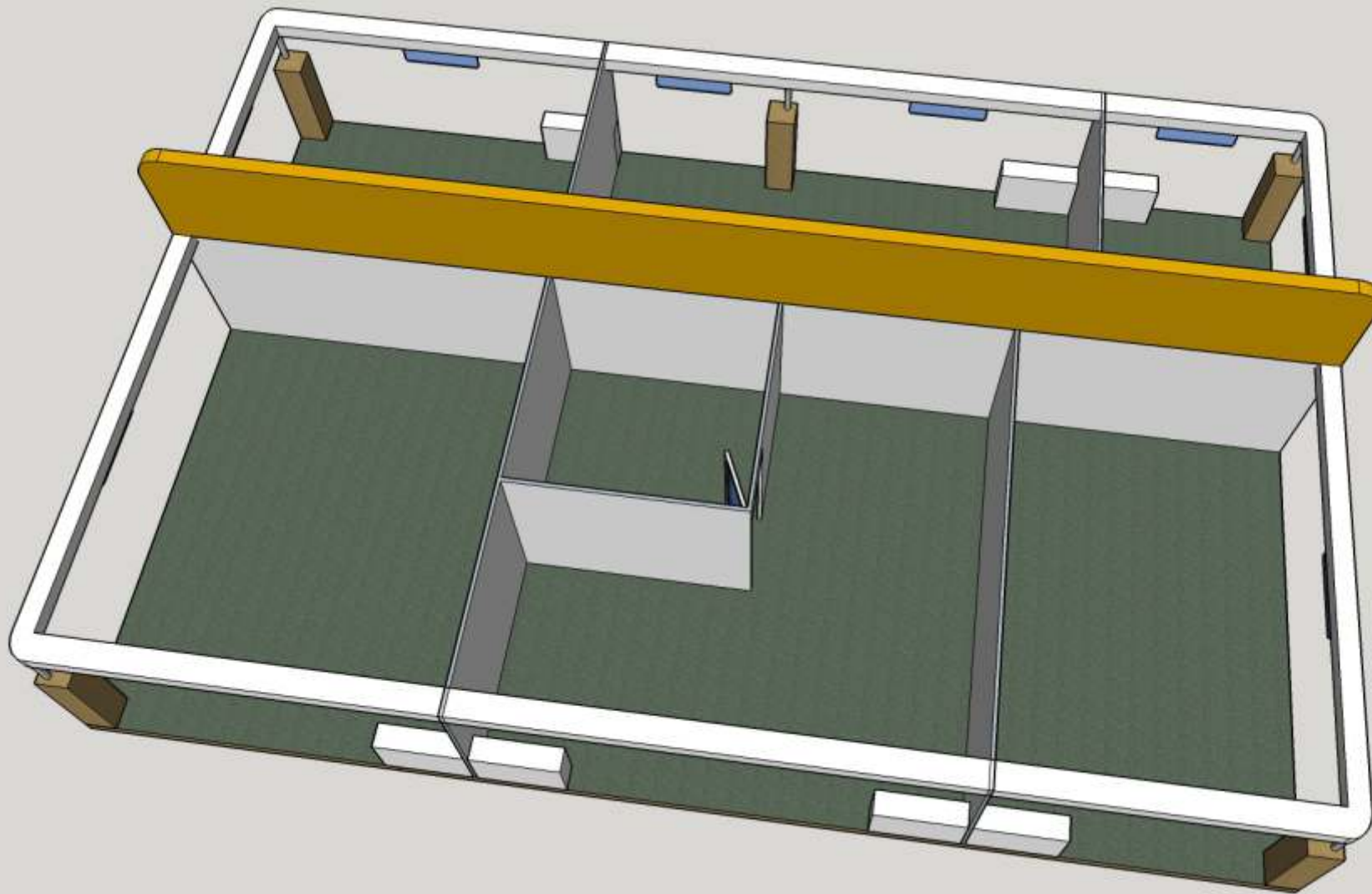

## Stand No. B 90

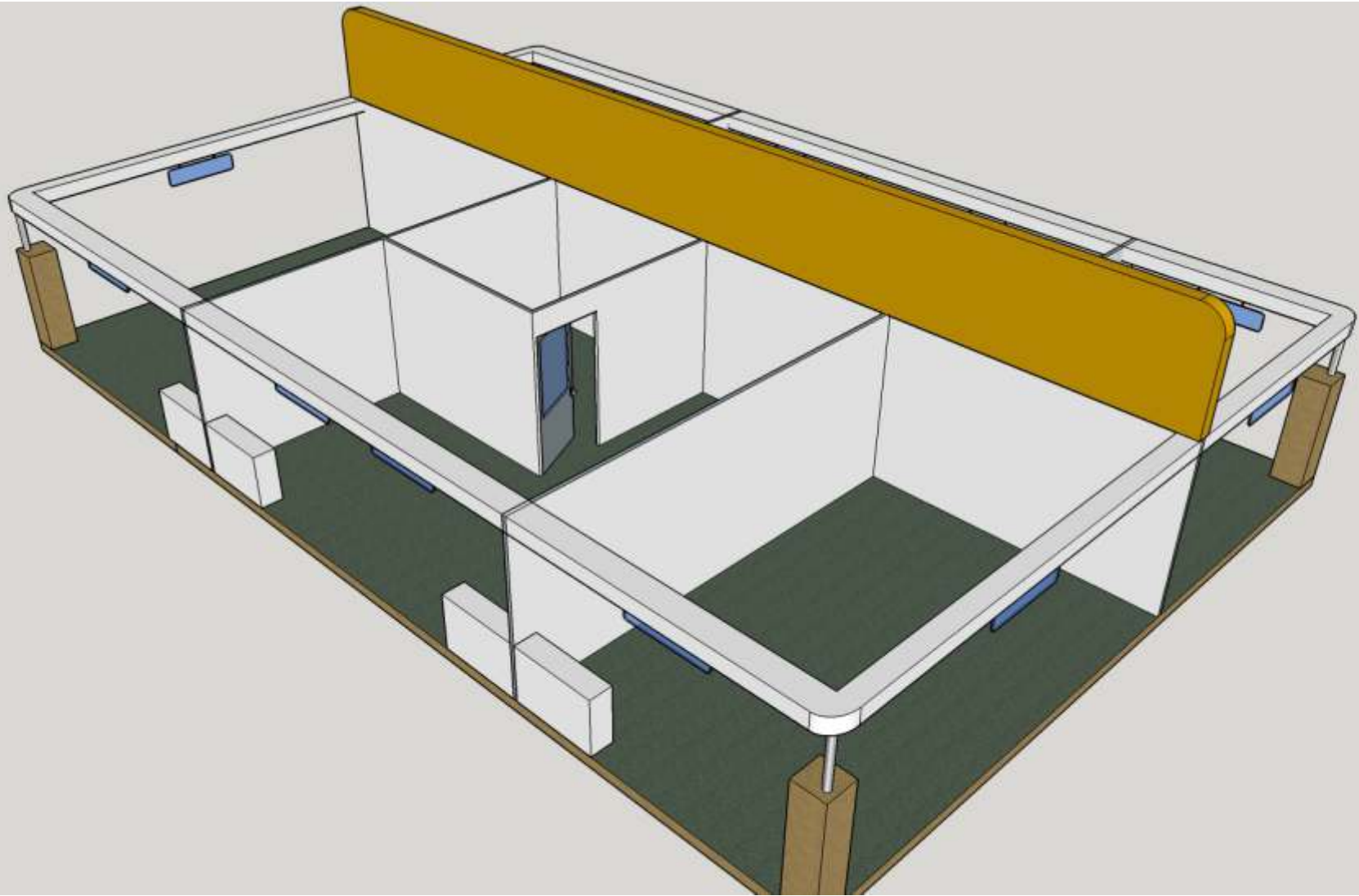

## Stand No. B 90

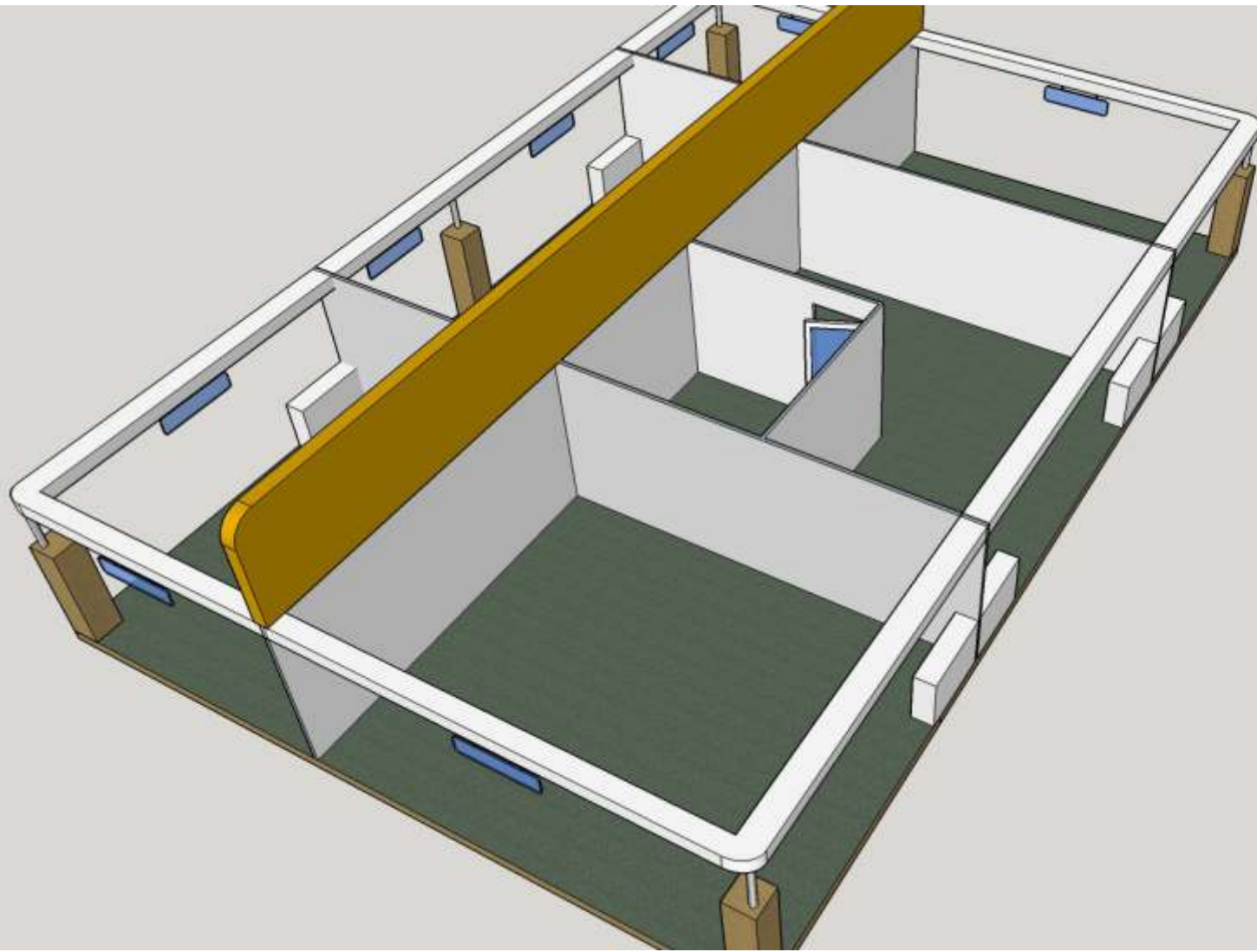

## Stand No. B 90

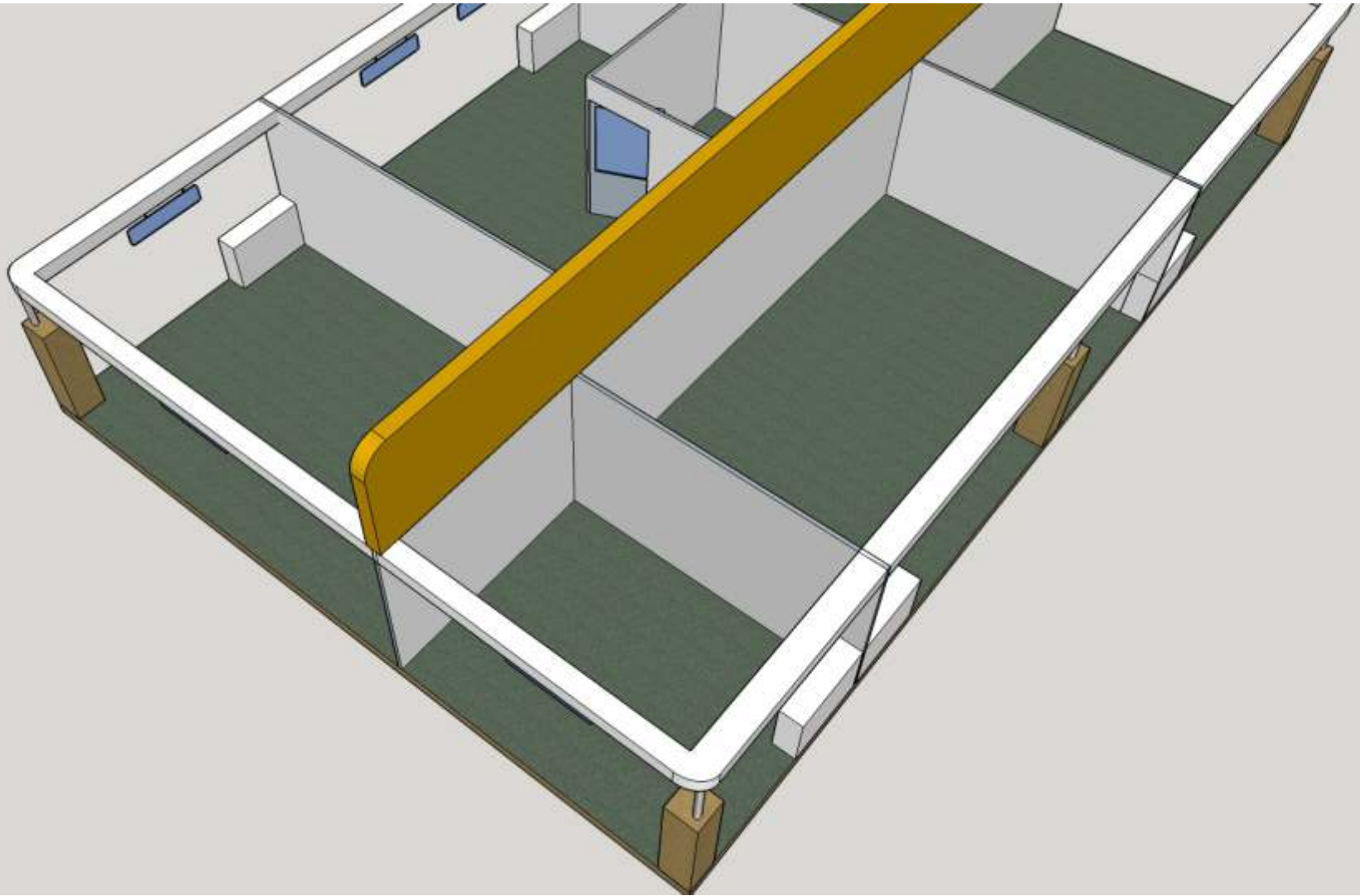

# Stand No. B 90

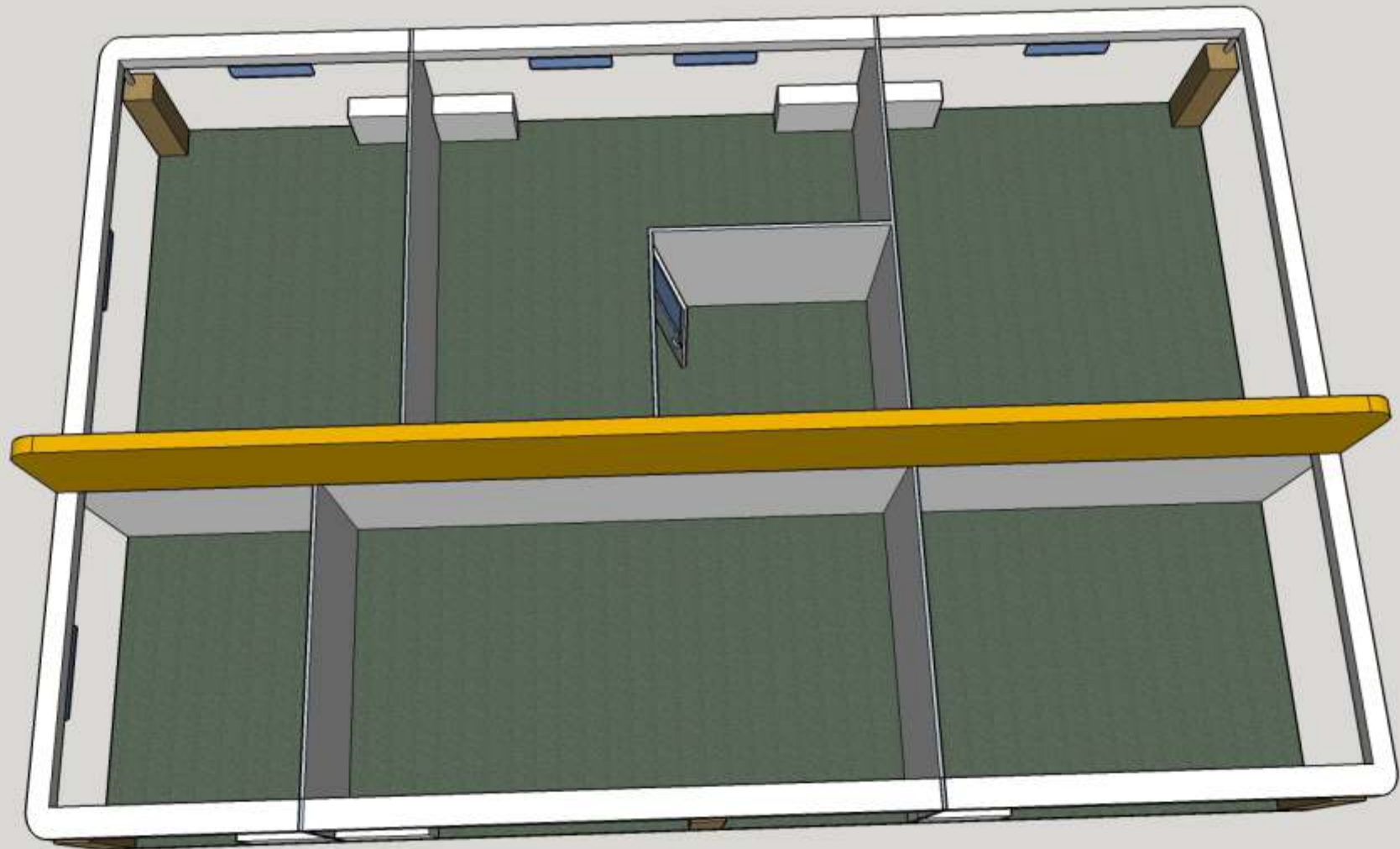



## Stand No. B 90

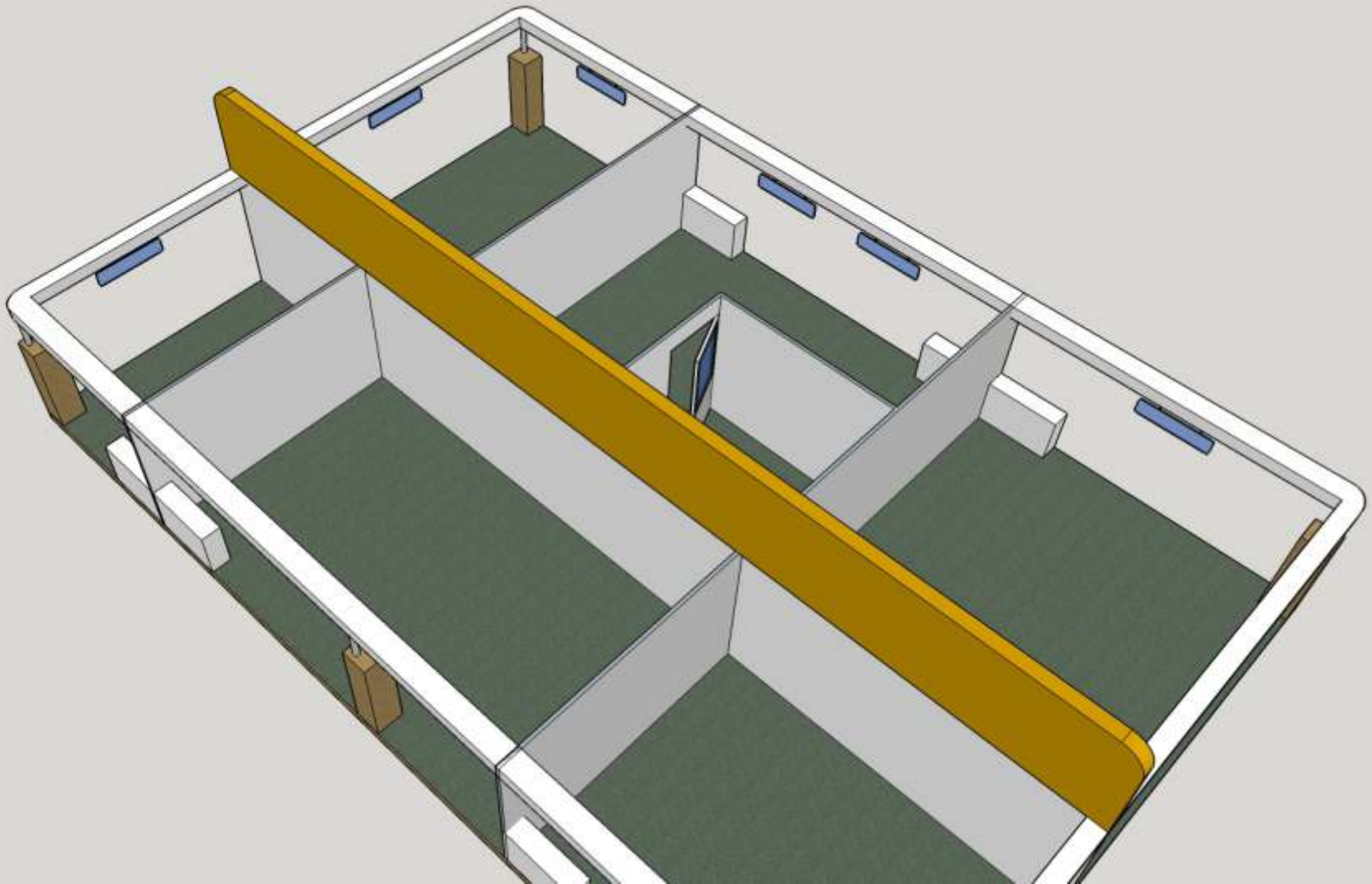

# Stand No. B 90

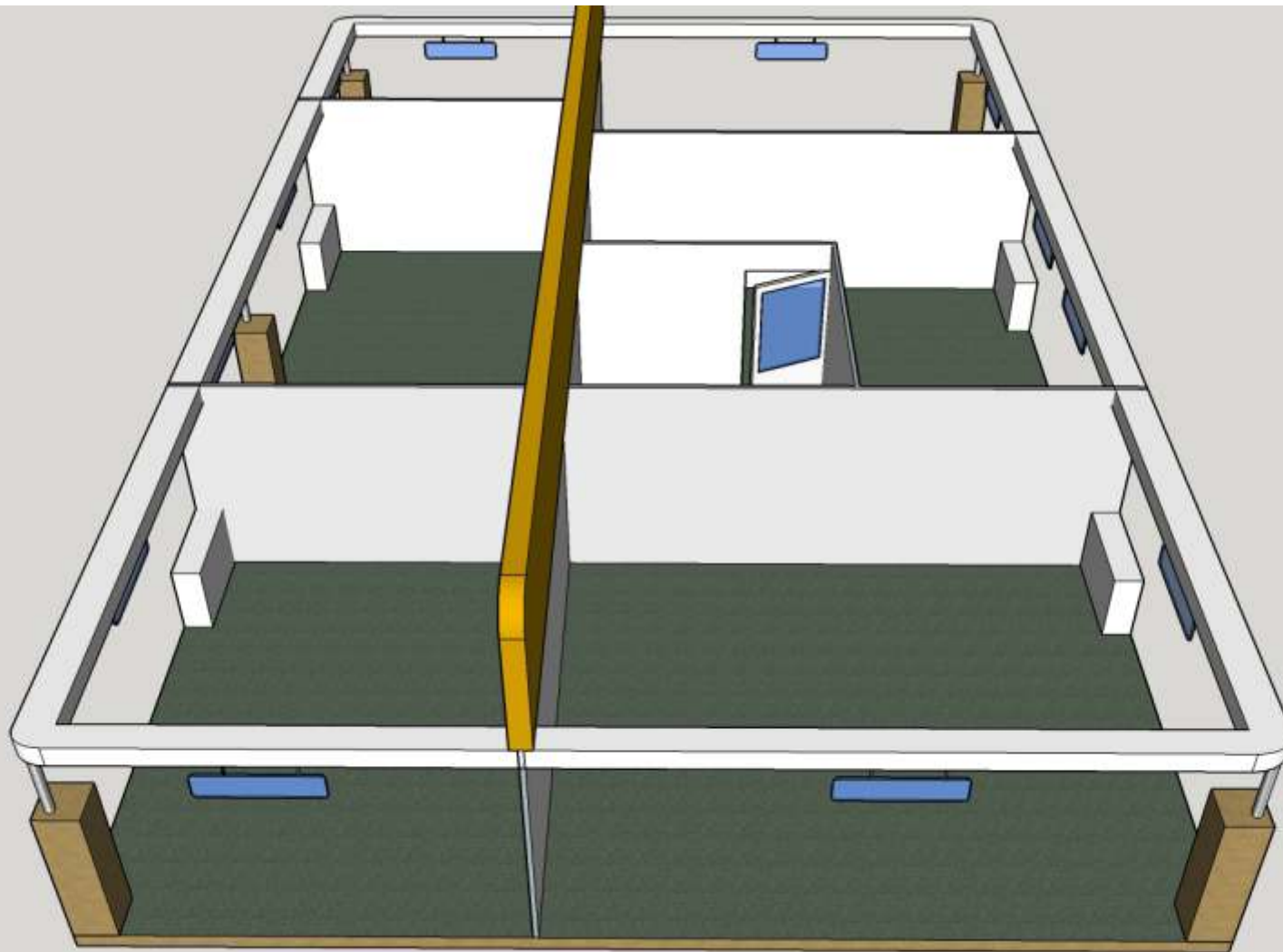

**Stand No. B 90**

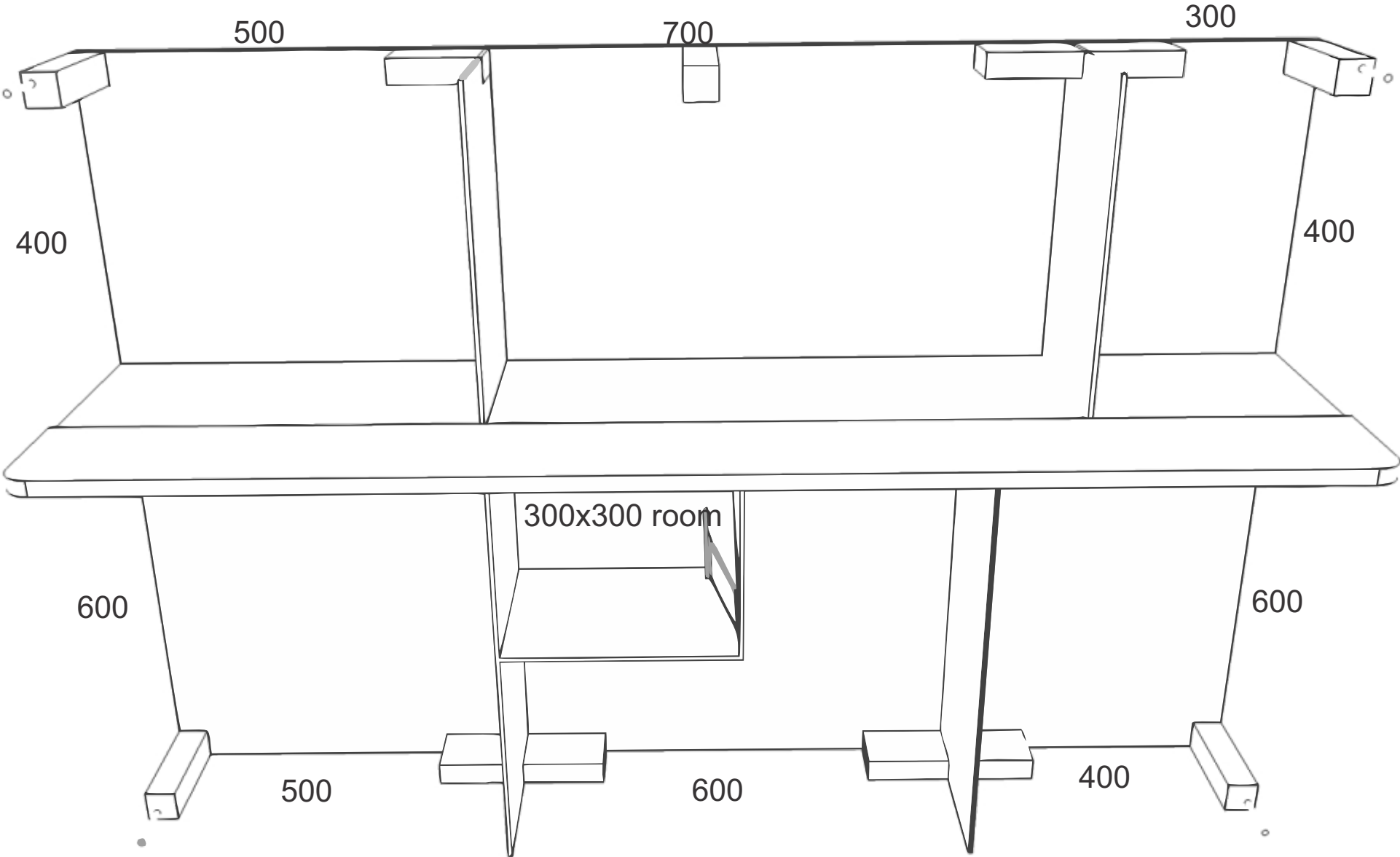

Domotex 2018  
Coir Boad pavilion in Stand Nos. B 90, F 79 & F 80  
Stand No. B 90

Stand No. B 90

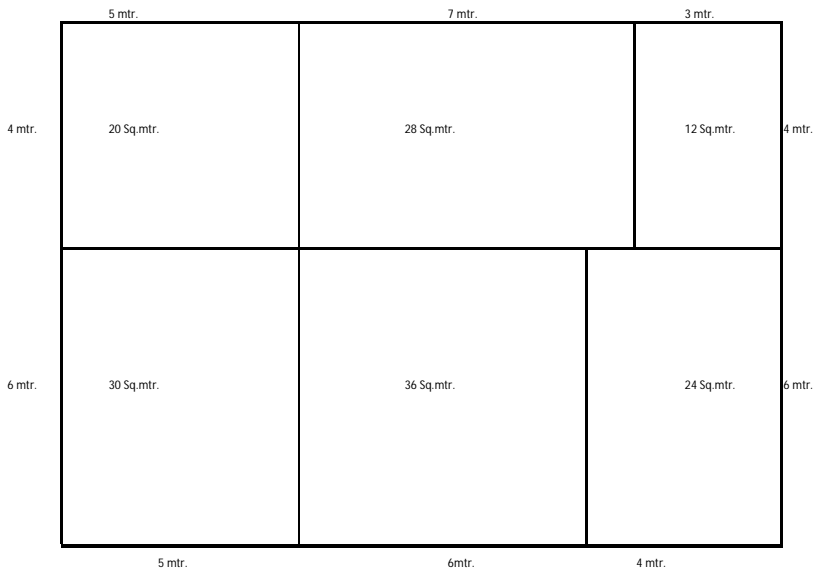

Stand No. F 79

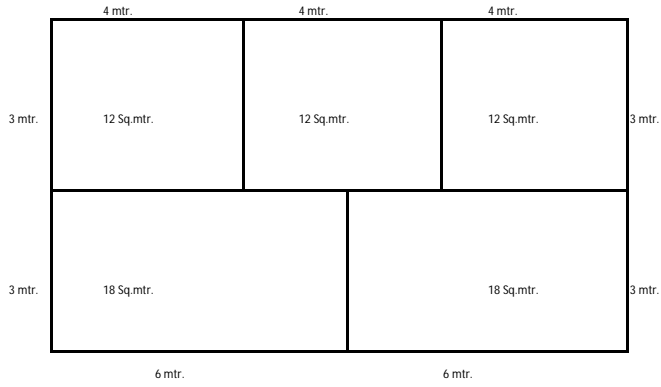

Stand No. F 80

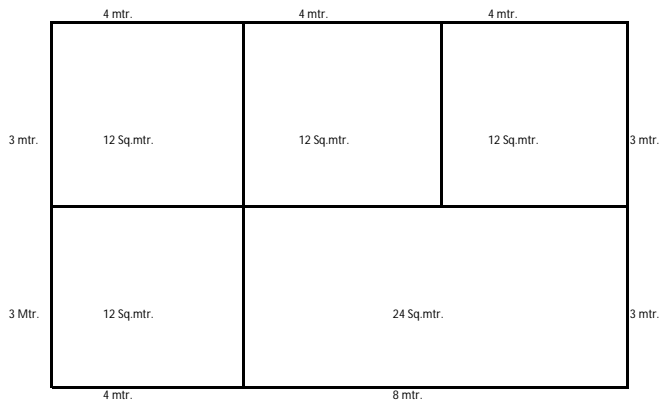



SYSTEMSCHNITT / VERTICAL CROSS SECTION

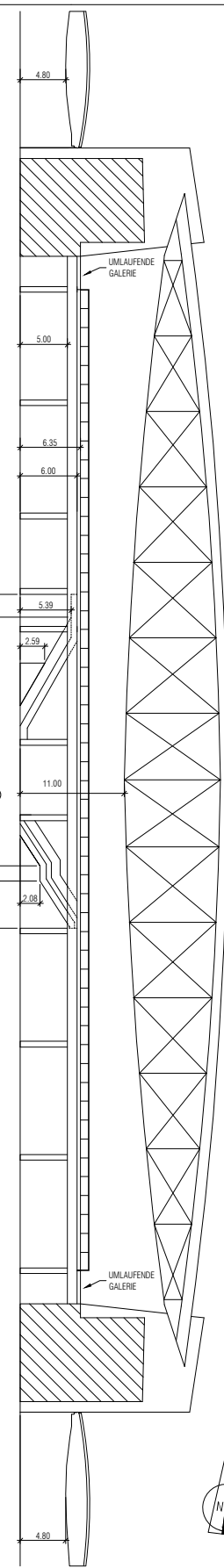

NUR FÜR DEN INTERNEN GEBRAUCH - NICHT ZUR VERÖFFENTLICHUNG  
FOR INTERNAL USE ONLY - NOT FOR PUBLICATION

STAND / AS OF:  
17.07.2017

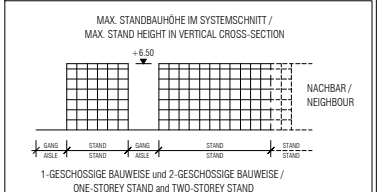

(C) DEUTSCHE MESSE AG. ÄNDERUNGEN VORBEHALTEN. VERÄNDERUNGEN NUR IN ABSPRACHE MIT DEM TECHNISCHEN AUSSTELLERSERVICE DER DEUTSCHEN MESSE AG / (C) DEUTSCHE MESSE AG. MODIFICATIONS RESERVED. ALTERATIONS PROHIBITED UNLESS APPROVED BY THE TECHNICAL SERVICES FOR EXHIBITORS DEPT. OF DEUTSCHE MESSE AG

ALLE MASSE SIND VOR ORT ZU PRÜFEN / ALL DIMENSIONS TO BE CHECKED ON SITE

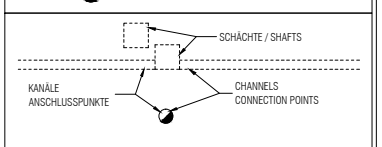

- ZUGANG GEWÄHRLEISTEN - DO NOT OBSTRUCT ACCESS -  
LICHT- HOHE = 5,00 m - 10,00 m JE STANDORT  
STELLENWEISE GERINGERE NUTZHOHE WIG. BAULICHER ENTSCHRÄNKUNGEN.  
MAX. HEIGHT CLEARANCE FOR EXHIBITS = 5.00 TO 10.00 m DEPENDING ON LOCATION.  
ACTUAL CLEARANCE LOWER IN SOME PLACES DUE TO ARCHITECTURAL SPECIFICS.  
MAX. FUSSBODENBELASTUNG / MAX. FLOOR LOAD 100 KN/M²  
(GILT NICHT AUF SCHÄCHTEN UND VERSORGENSKANÄLEN) / (NOT VALID FOR SHAFTS OR SUPPLY CHANNELS)

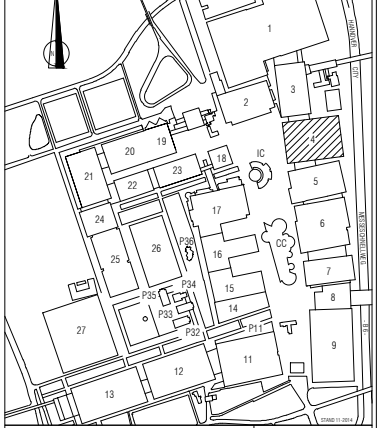

Deutsche Messe HALLE / HALL 4

VERMIETPLAN / RENTAL FLOOR PLAN  
DOMOTEX 2018